

# Unibilt<sup>®</sup>

## *Enclosed Track Conveyors*



***Quality***

***Performance***

***Reliability***

**Jervis B. Webb Company**  
MATERIAL HANDLING SYSTEM SPECIALISTS





## CONTENTS

### **Designing a Conveyor ..... 3 - 11**

Conveyor Component Symbols .....	4 - 5
Typical Overhead Conveyor Drawing .....	4 - 5
Conveyor Design Procedure .....	6 - 11

### **Conveyor Components ..... 12 - 31**

Universal Link Chain .....	12
Enclosed Track .....	13
Modular Track .....	13
Track Splices .....	14
Track Accessories .....	14
Standard Turns and Curves .....	15
Horizontal Turns .....	15
Vertical Curve Charts .....	16 - 18
Traction Wheel .....	19
Safety Stops .....	19
Drive Units .....	20 - 21

Chain Take-Ups .....	21
Chain Load Attachments .....	22 - 24
Lubricators .....	25
Carriers .....	26
Suspension Fittings .....	27

### **Additional Unibilt Products ..... 28-35**

Unibilt Over-N-Under .....	28-29
Hand-Pushed Trolley .....	30
Deep Track .....	30
Hand-Pushed Monorail .....	31
Stop-N-Flow Power & Free .....	32-33
Inverted Power & Free .....	34-35
Sales Facilities .....	Back Cover

# Unibilt®

## ENCLOSED TRACK CONVEYORS

*Designed and manufactured for quality, reliability, and low cost performance by the Jervis B. Webb Company.*

**Most conveyors are made to look like a Unibilt conveyor, but they're just not designed to give the reliable performance of a Unibilt conveyor.**

### TRACK

---

Unibilt Track is precision roll formed from patented WEBBALLOY II™ Steel— a specially formulated high strength carbon steel that is harder, stronger and designed to last longer — an exclusive feature of Unibilt track.

**Horizontal Turns and Vertical Curves-** 24" and 36" radius turns and vertical curves are heat treated on the wear surface for added anti-wear qualities.

### CHAIN

---

**Side Links-** Unibilt chain side links are heat treated for longer life.

**Wheels-** Unibilt chain wheels are machined, not stamped. Case hardened inner and outer bearing races are machined after heat treating. Ball bearings are made from high grade carbon steel for smooth operation and extended life.

**Symmetrical Chain Pins-** Unibilt symmetrical chain pins are precision drop-forged from carbon alloy steel, not stamped.

### DRIVES

---

Unibilt drive units have a unique drive overload cutoff design, not the higher maintenance slip clutch plate design.

**Please Note:** This catalog is designed to illustrate the various Unibilt components and their applications in a conveyor system. Although self design and installation of a Unibilt system are possible, we strongly recommend working with Unibilt personnel to achieve the correct application of Unibilt products. You should be aware that environmental and many other conditions may vary with each installation. The Jervis B. Webb Company does not warrant that adherence to any guidelines or suggestions set forth in this brochure will necessarily result in proper selection, manufacture, installation and maintenance of conveyor equipment and/or a conveyor system. Unless there are specific written specifications or recommendations and pursuant to a written contractual commitment from it, the Jervis B. Webb Company hereby disclaims all responsibility for any equipment and/or system malfunction, any violations of law, property damage, personal injury or any other damages resulting from equipment and/or system selection, design, installation, maintenance, or operation carried out by a contractor, user or any other person.

No purchases of Unibilt components shall constitute the granting (either expressly, by implication, estoppel or otherwise) of any license under any existing or pending patents of the Jervis B. Webb Company, its Divisions, Subsidiaries and Affiliates.

**The Jervis B. Webb Company** created the Unibilt product line in the early 1960s to provide manufacturers of all types with a multi-purpose enclosed track conveyor. Designed and built upon principles of increasing productivity, Unibilt Enclosed Track Conveyors incorporate reliability, economy, flexibility, and simple installation either by welding or bolting.

Unibilt Enclosed Track Conveyors contain many features normally associated with conventional I-Beam conveyors, plus features that are unique to this type of system, such as:

- Completely enclosed chain helps prevent accidental contact with moving parts.
- An enclosed track helps prevent contamination from reaching the chain or track bearing surfaces.
- The Unibilt heavy-duty chain with symmetrical chain pin is designed to provide maximum flexibility in all directions, featuring easy assembly or disassembly with simple hand tools.
- The enclosed track design helps provide protection from the elements for the chain and other moving parts.
- Shorter radius curves and closer spacing of curve tangents are possible due to the universal link chain.
- Easier installation...no bulky roller turns or traction wheels to erect.
- Caterpillar-type drive units provide flexibility for all enclosed track power requirements in a single compact package.

Qualified local distributors and regional Unibilt representatives are available to assist you in all phases of a conveying system: design/ engineering, plant layout, installation and application.

Unibilt Enclosed Track Conveyors offer a system that has applications in both simple and complex handling problems.

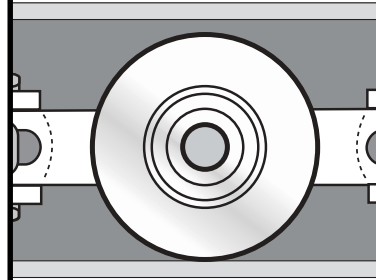
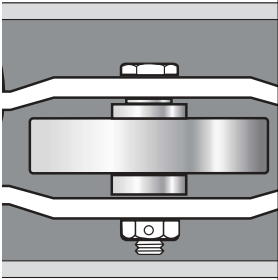

## *Designing a Unibilt Conveyor System*

All design should be in compliance with the latest edition of ANSI B20.1, and, among other things, the requirements of OSHA Lockout/Tagout standards. Design work should only be done by personnel with knowledge of these requirements.

On the following pages are illustrations of a typical conveyor layout, component symbols, and general step-by-step procedures that have been followed in many cases.

Shown on pages 4 and 5 is a plan view and an elevation view of a typical Unibilt overhead conveyor system. It is an example of the drawing technique and conveyor component symbols used by the conveyor industry in designing a system.

A list of conveyor data is given as a typical example of the components necessary to install the conveyor used in the example.

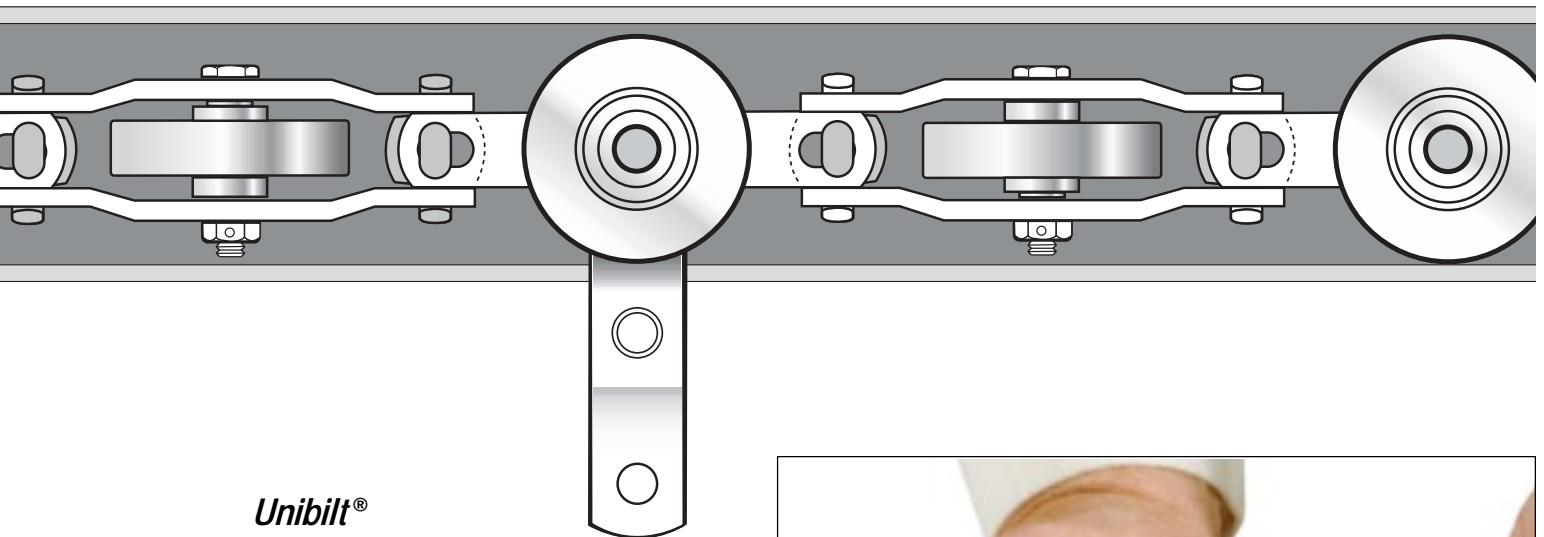

### ***Unibilt® Heavy-Duty Chain With Symmetrical Chain Pin***

Designed to provide maximum flexibility in all directions, universal link chain, developed by Unibilt, features symmetrical chain pins with a true universal joint at each pitch.

Easily assembled or disassembled with hand tools by removal or insertion of a single bolt at every pitch, universal link chain is completely heat-treated to assure strength and long life.



## Design Procedure

	Page
Step 1. Draw Plant Layout .....	6
Step 2. Draw Path of Conveyor .....	6
Step 3. Select the Chain Attachment .....	6
Step 4. Design a Carrier .....	6
Step 5. Determine Track Elevations .....	6
Step 6. Select Vertical Curves .....	7
Step 7. Select Horizontal Turns .....	7
Step 8. Determine Guard Requirements .....	7
Step 9. Determine Required Carriers Per Minute ...	8
Step 10. Determine Carrier Spacing .....	8
Step 11. Determine Maximum Conveyor Speed .....	8
Step 12. Determine Conveyor Length .....	8
Step 13. Determine Number of Carriers .....	8
Step 14. Determine Number of Loaded and Unloaded Carriers .....	9
Step 15. Determine Live Load .....	9
Step 16. Determine Lift Load .....	9
Step 17. Determine Chain Pull .....	9 & 10
Step 18. Determine Drive Size and Location .....	10
Step 19. Suspension Methods .....	10
Step 20. Summary and Installation .....	11

### Conveyor Data:

Conveyor Length ..... 280 ft  
 Conveyor Speed ..... 30 fpm  
 Oven Temperature ..... 225°  
 Voltage ..... 230  
 Phase ..... 3  
 HZ ..... 60  
 Take-Up Type ..... Spring  
 Horizontal Turns ..... 24" R.  
 Vertical Curves ..... 24" R. 45°  
 Product Weight ..... 40#  
 Carrier Weight ..... 9.5#  
 Carrier Spacing ..... 4'0 3/4"  
 Live Load ..... \_\_\_\_\_

### Provided by customer:

*Electrical Controls, Carriers,  
 Installation, Supports and Hanging Steel*

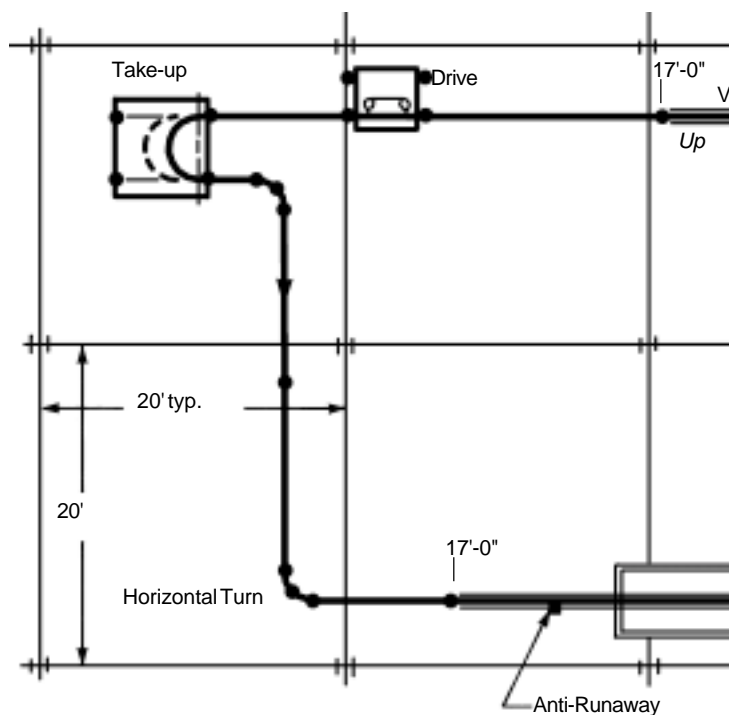
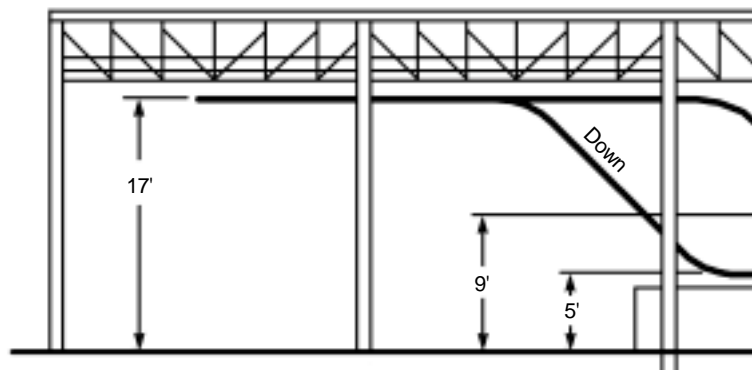

### Conveyor Component Symbols

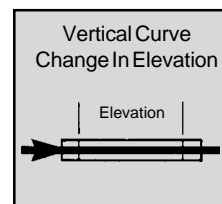
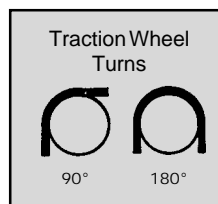
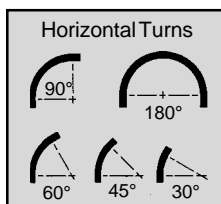
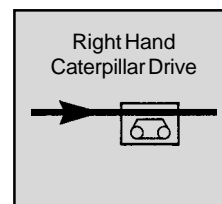
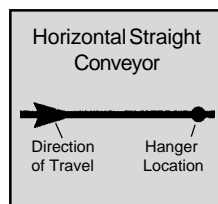

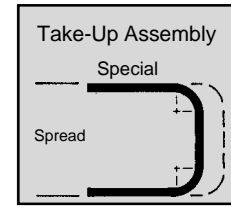
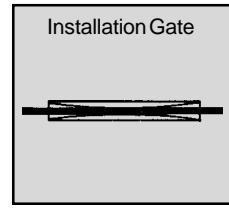
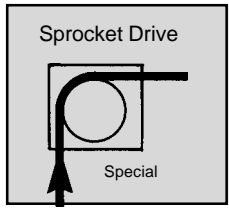
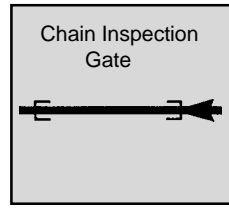
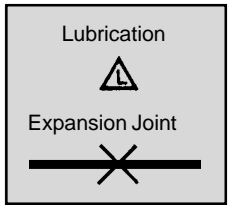
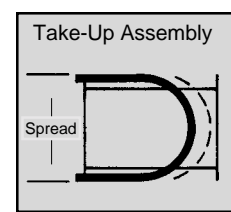
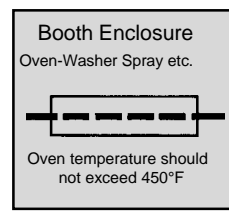
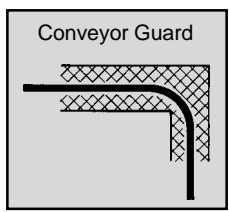
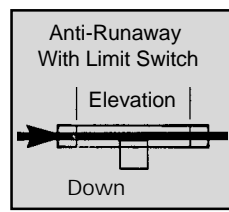
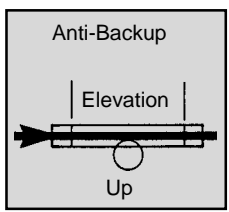
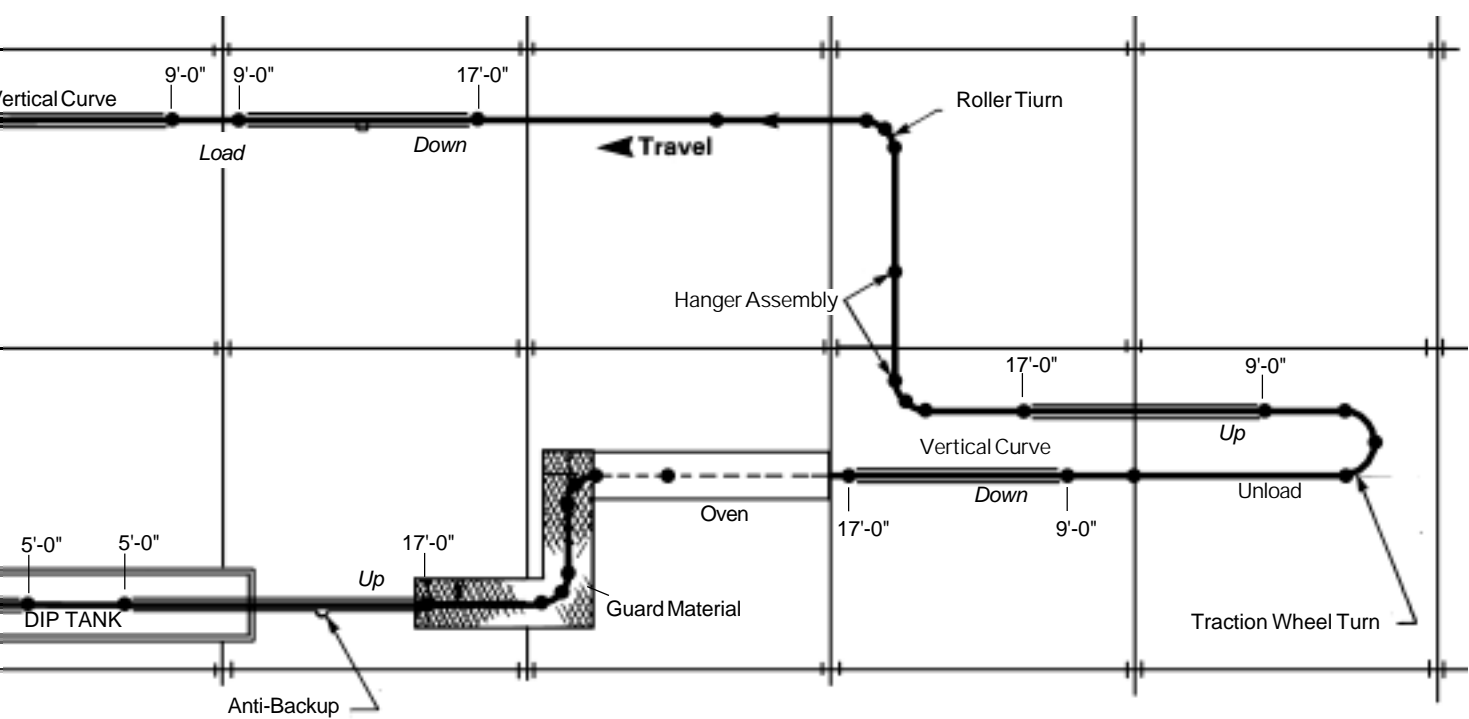
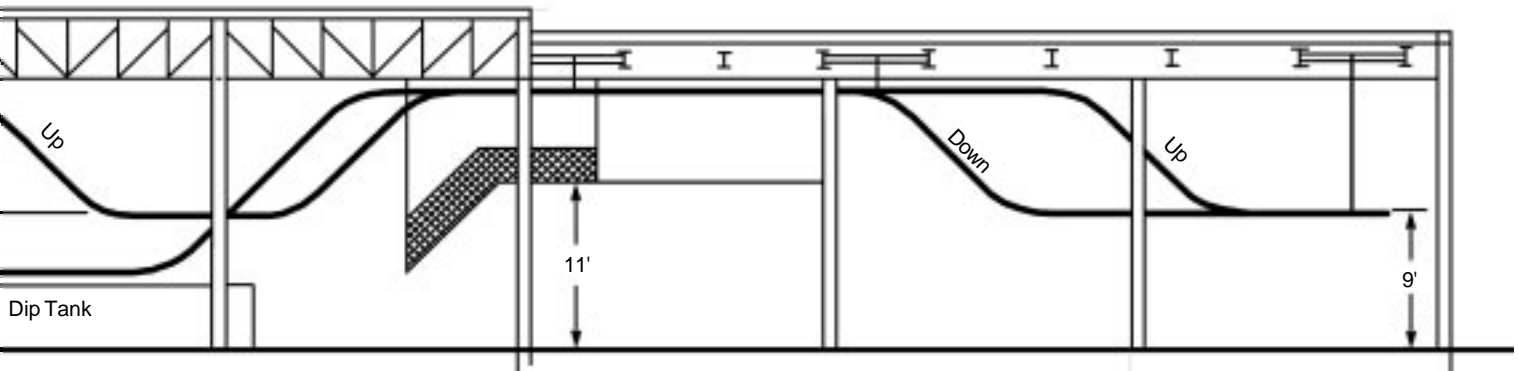

*The following step-by-step procedure will illustrate general principles used in designing a Unibilt Enclosed Track conveyor system.*

## **1 Draw Plant Layout**

- Draw layout to largest possible scale, for example: 1/4" = 1'-0".
- Make a plan view of plant area where conveyor is to be erected. Show dimensioned column or bay lines.
- Show and label all obstructions in the path of conveyor, such as columns, walls, machinery, work areas and aisles.
- Indicate "North" direction relative to building. Refer to typical layout for example.

## **2 Draw Path of Conveyor**

- On plant layout, locate all loading and unloading areas, as well as any processing stations that will be served by the conveyor. Typical stations: dip tanks, paint booths, bake ovens, etc.
- Draw conveyor route so that it connects all areas in their proper work sequence. Keep parallel conveyor routes as closely spaced as possible. This will reduce amount of supporting members and guards required.
- Be sure the path of conveyor does not interfere with any machine operations or other work areas.
- Indicate location of drives, vertical curves, horizontal turns, etc., relative to column lines. Refer to typical layout and conveyor symbols.

## **3 Select the Chain Attachment**

- Chain attachments can be selected from the illustrations on pages 22, 23 and 24.
- Select the attachment to which the load or carrier can most easily be attached, keeping within the load ratings.
- Attachments illustrated on pages 22, 23 and 24 are standard stock attachments. Almost any type of attachment can be fabricated on special order to suit specialized applications. (In our example, we are using attachment V21298.)

## **4 Design a Carrier**

- Some examples of carrier designs are shown in this catalog.
- Determine number of parts to be placed on each carrier. Loads must be balanced.
- Design carrier bracket to fit chain attachment.
- Design of carrier should permit easy loading and unloading of parts, yet hold product securely during transportation.
- Do not design the carrier to sustain more weight than the rated capacity of the attachment.

## **5 Determine Track Elevations**

- Elevations are measured from floor line to top of track.
- At loading and unloading areas, the conveyor height must permit a person to easily load and unload the carrier.
- Over work areas and aisles, an accepted clearance is 7'0" from floor to bottom of guard. However, over aisles where industrial trucks, etc., are used, the conveyor height must allow traffic to pass freely.

## 6 Select Vertical Curves

- Using the figure below, select a degree of incline for vertical curves that will provide a clearance between carriers when they are on incline runs. Also, to assure clearance between carriers, dimension "A" must be greater than single carrier length.

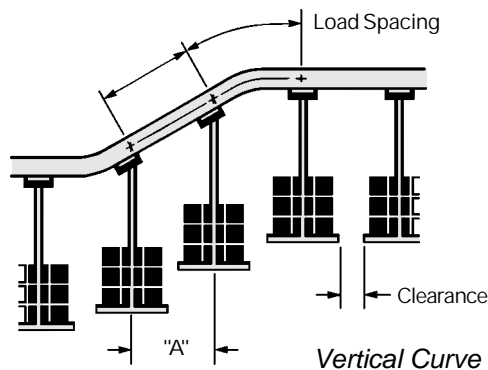

- Select a load spacing.
- Because carriers swing, clearance must be provided between top of carrier and track.
- Select vertical curves from vertical curve section.
- Indicate on drawing the horizontal length of each vertical curve from tangent to tangent.
- Locate each vertical curve relative to some adjacent component or column as shown on Typical Conveyor Layout.

### Work Clearance Limits for Vertical Rises and Drops.

Work Centers - Level		Work Centers On Slopes		
Nominal	Actual	30 Degree	45 Degree	60 Degree
2 ft	8-1/8"	7-1/16"	5-3/4"	4-1/16"
	16-1/4"	14-1/8"	11-1/2"	8-1/8"
	24-3/8"	21-1/8"	17-1/4"	12-3/16"
4 ft	32-1/2"	28-3/16"	23"	16-1/4"
	40-5/8"	35-3/16"	28-3/4"	20-5/16"
	48-3/4"	42-1/4"	34-1/2"	24-3/8"
6 ft	56-7/8"	49-1/4"	40-1/4"	28-7/16"
	65"	56-5/16"	46"	32-1/2"
	73-1/8"	63-3/8"	51-3/4"	39-9/16"
8 ft	81-1/4"	70-3/8"	57-1/2"	40-5/8"
	89-3/8"	77-7/16"	63-1/4"	44-11/16"
	97-1/2"	84-7/16"	69"	48-3/4"
10 ft	105-5/8"	91-1/2"	74-3/4"	52-13/16"
	113-3/4"	98-9/16"	80-7/16"	56-7/8"
	121-3/8"	105-9/16"	86-3/16"	60-15/16"

Rounded out to the nearest 1/16".

## 7 Select Horizontal Turns

- Make a plan view layout of horizontal turn as shown in figure below. Clearance between adjacent carriers when they are negotiating turns will determine the minimum horizontal turn radius and carrier centers.
- For increased conveyor life, use the largest standard radius horizontal turn possible in your layout. See the horizontal turn section.

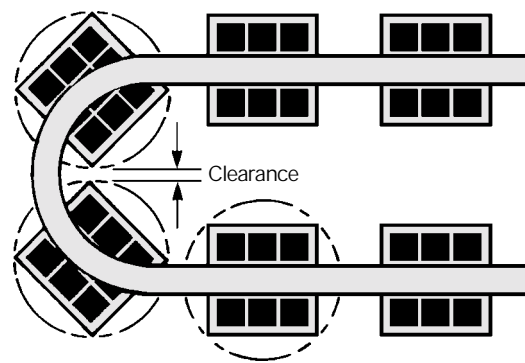

Horizontal Turn

## 8 Determine Guard Requirements

- For standard guard methods, refer to Guard Section. All guards must meet OSHA and ANSI B20.1 specifications.
- Select type of conveyor guard best suited to your requirements.
- Be sure loaded carriers will clear all guards. It is especially important to check clearances on horizontal and vertical curves. Carrier templates can be used for this purpose.
- Locate each guard relative to some adjacent component or column line as shown on Typical Conveyor Layout.

## 9 Determine Required Carriers Per Minute

- How many parts are to be handled per minute at maximum speed?
- You have designed a carrier that will carry a specific number of parts. The following typical example will best explain the proper procedure:
  - a. Assume your production rate is 900 pieces per hour.
  - b. Assume each carrier holds two (2) parts.

Required number of carriers per hour equals  $900/2$  or 450 carriers per hour.

Required number of carriers per minute is  $450/60$  or 7.5 carriers per minute.

## 10 Determine Carrier Spacing

- Carriers can be spaced on a minimum of 8-1/8" centers or a spacing of any multiple of 8-1/8".
- Refer to Step "5" and Step "6", number 1, and note the minimum carrier spacing determined for proper clearances.
- Carriers can now be spaced for adequate clearances at multiples of 8-1/8".

## 11 Determine Maximum Conveyor Speed

- A speed of 64.2 feet per minute is usually considered maximum. However, 30 FPM allows easy loading and unloading and assures longer conveyor life.
- Required conveyor speed in feet per minute is equal to the number of carriers per minute multiplied by carrier spacing in feet.

- To illustrate this formula:
  - a. In Step "9" we determined that 7.5 carriers per minute are required.
  - b. Assume a carrier spacing of 48-3/4" or 4 feet nominal.
  - c. 7.5 carriers per minute multiplied by carrier spacing of 4 feet equals a conveyor speed of 30 FPM.
- To allow for variation in production requirements, it is advisable to set a maximum speed of about two times that calculated, and use a variable speed drive with a speed range of about 3-to-1.
  - a. A speed two times greater than the calculated 30 FPM is 60 FPM.
  - b. Using a 3-to-1 ratio variable speed drive would give you a speed range of 20 FPM to 60 FPM.
- Refer to drive section for variable and constant speed drive information.

## 12 Determine Conveyor Length

- Obtain the sum of all straight track dimensions.
- Obtain the sum of all arc lengths on the horizontal turns by using the horizontal turn and take-up developed lengths. See diagram on page 15.
- Obtain the sum of all arc lengths on the vertical curves by using the vertical curve charts on pages 16, 17 and 18.

## 13 Determine Number of Carriers

- The required number of carriers is equal to the total conveyor length divided by the carrier spacing.
- In our example, conveyor length 280'-3-3/4"  $\div$  carrier spacing of 48-3/4" = 69 carriers.

## 14 Determine Number of Loaded and Unloaded Carriers

- Establish distance from loading to unloading points.
- Divide this distance by carrier spacing. In our example:
  - a. Assume the distance from loading to unloading points is 192' with a 4-foot nominal carrier spacing.
  - b. Total number of loaded carriers is  $192' \div 4 = 48$  loaded carriers.

## 15 Determine Live Load

- The live load on a conveyor is equal to the sum of the weights of the chain, attachments, carrier and product.
  - a. Multiply weight of the chain (3.75#) by the number of feet of chain. In our example  $280' \times 3.75\# = 1050\#$ .
  - b. Multiply weight of attachments by the required number of empty carriers. In our example  $.5\# \times 69 = 34.5\#$ .
  - c. Multiply weight of empty carrier by required number of carriers. In our example  $9.5\# \times 69 = 655.5\#$ .
  - d. Multiply weight of product only by number of required loads. In our example  $40\# \times 48 = 1920\#$ .
  - e. Totals of a, b, c, d = total live load on conveyor = 3660#.

## 16 Determine Lift Load

The lift load is the amount of force required to pull the live load upward along the vertical curves in the entire system.

To calculate this force, determine the change in elevation of all the loaded vertical curves traveling upward in the system. This net vertical rise (feet) will be considered the total lifting height of the conveyor.

The lift load for the elevation changes of the conveyor is equal to the total lift height (feet) multiplied by the individual load weight (pounds) then divided by the load spacing feet.

Example:

- a. Per our sample layout there are three vertical curves traveling upward adding to a total rise height of 28'

$$(8'-0 + 8'-0" + 12'-0")$$

- b. The load on each carrier is 40# and carriers are on 4'-0" (four) foot centers.

$$\text{Lift load} = 28' \times 40 \div 4 = 280 \text{ lbs.}$$

The chain, trolleys, and carriers are excluded from the calculations because they are balanced by the portion of the system that moves down vertical curves.

To pull a loaded moving conveyor up any incline requires a certain amount of continuous force or horsepower. This requirement, however, is frequently compensated by a loaded decline of the same length further along the conveyor and, therefore, can be ignored. Starting conditions, however, often impose an exception to this rule, since at the start of production when the conveyor is first loaded, inclines could be loaded without normally loaded balancing devices.

## 17 Determine Chain Pull

Chain pull is the effort necessary to maintain the normal operating speed of a conveyor under a rated capacity load. To arrive at this figure, it is necessary to add the lift load and the friction factors, expressed as a small percentage of the live load, which act as resistance to the progress of the conveyor. The live load and the lift load were calculated in Steps 15 and 16.

### Determine Chain Pull Cont.

Frictional resistance is found in the bearings of the trolley wheels, roller or traction wheel turns, and the drive unit itself. This friction figure is represented as a small percentage. It should be noted that these percentages are for average conveyors that travel under normal conditions. When adverse environmental conditions exist or the conveyor is abnormally long or complex and exceeds the chain pull capacity of one drive, a progressive chain pull computation is necessary where the friction losses are progressively calculated and accumulated through the path along the conveyor. Contact your Unibilt representative for these conditions.

Using a 2-1/2% friction factor will cover most normal conditions.

**Note: A large number of vertical and horizontal curves will create slightly higher friction.**

To determine chain pull due to friction, multiply total moving load by selected friction factor. Using figures from previous examples, the following illustrates proper procedure.

- a. Total live load (from Step 15) ..... 3660 lb
- b. Multiply by friction factor ..... 0.025  
Friction chain pull ..... 91.5 lb

Add lift load to friction chain pull to obtain total chain pull.

- a. Friction chain pull ..... 91.5 lb
- b. Lift load (from Step 16) ..... 280.0 lb  
Total chain pull ..... 371.5 lb

### 18 Determine Drive Size and Location

- The drive must pull - not push - the load.
- Locate the drive so it will apply a pulling force on the most heavily loaded portion of the system.
- For best results, locate the drive at the highest level in the conveyor system and place the take-up just after the drive in the direction of chain travel, preferably at the lowest point.
- Show selected drive location on conveyor layout. Relate location to some adjacent component as shown in Typical Conveyor Layout.
- Drives are available in 300# and 600# capacities. For multiple drive systems, consult your Unibilt representative.
- Chain pull that is greater than 300# requires a 600# drive.

### 19 Suspension Methods

- Determine the method of attaching hangers to your building as illustrated in the back of the catalog.
- To arrive at the accurate suspension centers, a live load per foot figure must be determined. Live load weight per foot is the total weight of all products, carriers, attachments, and chain. Using figures from previous examples, the following example illustrates the proper procedure:

V20200 Series Track	Uniform Live Load - lb/ft				
	15.0	25.0	35.0	50.0	60.0
Span - feet	15.5	13.5	12.5	11.5	10.5
Deflect - inches	0.75	0.67	0.59	0.57	0.47

	Uniform Live Load - lb/ft				
	75.0	100.0	200.0	250.0	250.0
Span - feet	10.0	9.0	8.0	7.5	6.5
Deflect - inches	0.75	0.67	0.59	0.37	0.28

- A. Total Live Load 3660 lb
- B. Divided By Chain Length 280 ft
- C. Live Load Per Foot 13.1 lb/ft

At 13.1 lbs./ft., support centers can be up to 15'-6".

- Determine the number and type of clamps and track splices required to suspend the conveyor from your building steel.
- The track should be suspended at every splice when using bolted connection V8671.
- When using welded-style splices, the track should be suspended at the horizontal turns, at the top and bottom of the vertical curves and at all four corners of the drive and take-up.
- Determine the approximate length of each hanger and sway brace from the dimensions shown on the typical suspension methods.

Because of the difficulty of calculating the exact length of each hanger or sway brace, they are shipped in 12'-0" long threaded lengths and cut to suit when the conveyor is erected.

Special hangers or sway braces can be ordered cut to length up to 20'-0" long with 12" of thread on each end.

- If overhead suspension is impossible or impractical, floor supports can be furnished to suit individual needs.

---

## 20 Summary and Installation

For quick and easy reference, make a legend on a layout covering the following subjects:

(Refer to typical conveyor layout and legend)

- a. Speed of conveyor - mark direction of travel
- b. Length of conveyor
- c. Carrier spacing
- d. Total number of carriers
- e. Number of parts on each carrier
- f. Weight of carrier
- g. Weight of part on carrier
- h. Live load (chain, attachment carrier & load)
- i. Electrical specifications
- j. Guard cross-section with dimensions
- k. Chain pull

Make a list of all components required to complete your conveyor system.

The following is a suggested check list:

- a. Horizontal turns (degree and radius)
- b. Take-up
- c. Drive & safety guards
- d. Vertical curves (degree and radius)
- e. Chain attachments
- f. Chain length
- g. Guard material
- h. Carriers
- i. Header and hanger steel
- j. Maintenance and inspection gate
- k. Track straight sections
- l. Track splices or hangers
- m. Lubrication
- n. Traction turns
- o. Anti-backup
- p. Anti-runaway expansion joints

The design procedure outlined above assumes the existence of certain environmental and other conditions.

For example, the following conditions preclude effective use of the design procedure set forth above:

- a. Adverse atmospheric conditions such as alkali washes, bonderite, dust or grit.
- b. Oven temperatures above 450° F.
- c. Conveyor speed above 60 feet per minute.
- d. All vertical curves should be balanced.

To pull a loaded conveyor up an incline requires a definite amount of horsepower. To compensate for this requirement, there is generally a loaded decline of the same length to balance the load being lifted. The horsepower required to lift the load is then not reflected back into the horsepower requirements of the drive. When the conveyor is loaded at one elevation and is unloaded at a higher elevation, a Webb Regional Manager should be consulted to make sure that the drive capacity is adequate.

**The conditions set forth above are intended to be examples and are not exhaustive. There may be other conditions that preclude use of the design procedure set forth above. We recommend that all self-designed systems be checked by a conveyor engineer who is thoroughly familiar with the design capabilities of Unibilt conveyors and the special precautions necessary when operating in adverse conditions or when conveyors are abnormally long or complex.**

You may contact your local Webb Regional Manager. He has had wide experience on all types of conveyor systems and components. His services are available for surveying your plant, inspecting your layout and assisting or designing a system for your needs.

The Unibilt Enclosed Track Overhead Conveyor has been designed to be erected either by bolted construction, or by welded construction when experienced welders are available. Sections in this brochure on installation illustrate various methods and components used to erect a Unibilt Enclosed Track Overhead Conveyor. Careful study of this section will help in selecting the equipment and method best suited to install your particular system.

**We wish to caution you that conditions at your plant may be such as to dictate a particular installation method and specific components and such conditions could preclude use of installation methods set forth in this brochure.**

*The Jervis B. Webb Company has a staff of erection superintendents strategically located throughout the United States and Canada. Webb Regional Managers in your area can procure the services of these experts to assist you in any or all phases of your conveyor installation.*

## Chain...the Heart of the System

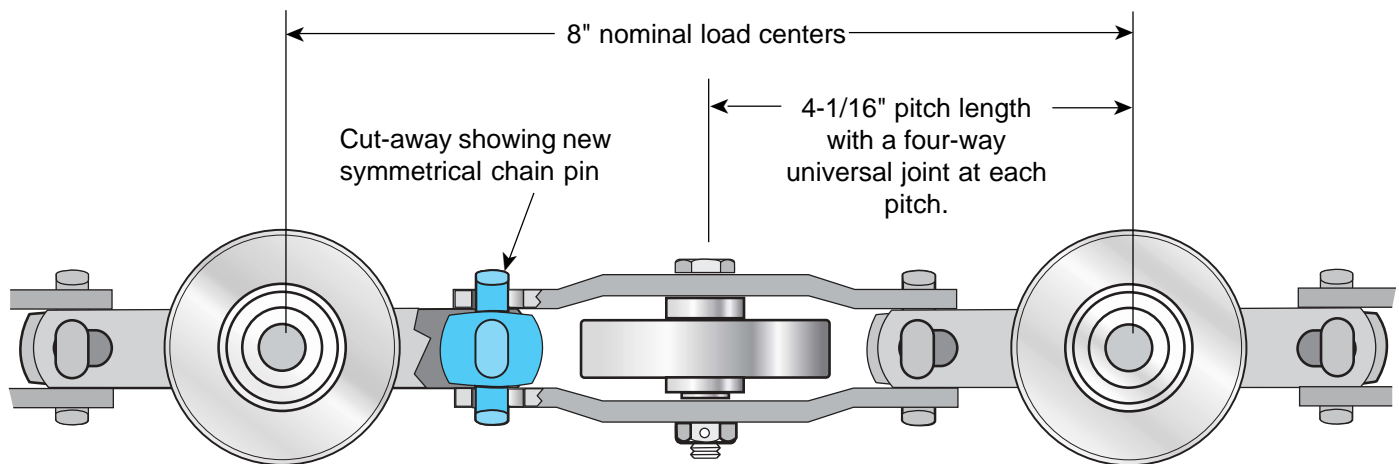

Stamped side links of high carbon steel, heat-treated for maximum strength and wearability.

Weight: 3.75 lb per foot

**Unibilt Heavy-Duty Chain with symmetrical chain pin is designed to provide maximum flexibility in all directions with a true universal joint at every pitch.**

Some of its outstanding features are:

- Both lateral and vertical load-carrying wheels are ball bearing style, made of machined steel with machined ball bearing races. Heat-treated steel balls are used. All wheel parts are heat-treated to provide maximum life.
- The symmetrical chain pin is high carbon steel and heat-treated for long life, added strength and ease of installation.
- The ultimate strength of this chain is over 10,000 pounds, providing a safety factor of over 16-to-1 when used at recommended chain pulls (item 17, page 10).
- Easily assembled and disassembled, the chain can be disassembled at every pitch by removing the axle bolt on the lateral guide wheel. The chain can then be flexed 90 degrees and the side links removed.
- Heavy-duty chain is available with steel core wheels with nylon tires for noise reduction.
- The heavy-duty chain comes in 20' lengths (nominal).
- 125 pound capacity on 8" nominal centers.



**Unibilt Heavy-Duty Chain V27826 (Steel)**

Maximum temperature:  
up to 450°F w/proper lubrication



**Unibilt Heavy-Duty Chain V27827 (Nylon)**

Maximum temperature:  
up to 120°F w/proper lubrication

## Unibilt Enclosed Track

Enclosed Track ..... 10'0" Lg. V20200

Enclosed Track ..... 20'0" Lg. V16997

\* #304 Stainless Steel ..... 20'0" Lg. V16999



Weight: 4.8 lb per foot

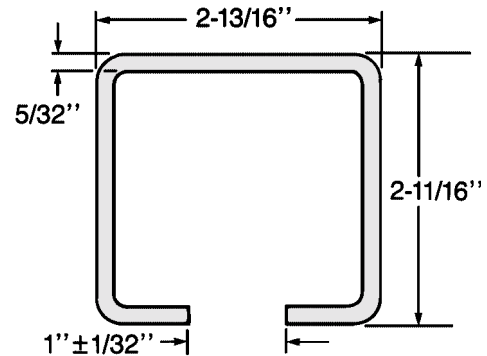

The Unibilt Enclosed Track V20200 is a square tubular section formed of 5/32" high strength Webballoy II steel. The yield strength of this steel is about 26% greater than plain carbon steel, allowing the track to be formed in lighter sections and still maintain its strength and rigidity over long spans.

The lighter weight makes it easier to handle and imposes less load on the conveyor hangers and the building structure.

This special alloy steel has greater abrasion resistance and better load-carrying characteristics than plain carbon steel, assuring longer life under most service conditions.

The track can be welded using AWS E7018 low hydrogen rod or E71T1 wire and can be saw-cut in the field without special tools. Unibilt track is available in 10' or 20' lengths. The external surfaces of the tracks are painted our standard "Unibilt Blue."

\* Unibilt stainless steel track is recommended for use through parts washers and corrosive environments.

## Modular Track

### Unibilt End Yoke V72117

The Unibilt End Yoke features a patent pending design that aligns the track sections together for bolted connections. (Nuts and bolts not included.)

The end yokes are welded to the ends of the track, turns, curves, etc. with fixture precision for positive alignment.

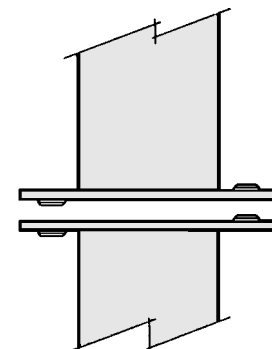
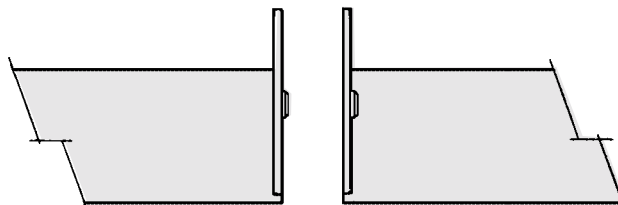

## Track Splices

### Splice Clamp V8624 Welded Splice Connection

Weight: 5 lb



This welded type of track splice is recommended where experienced welders are available. It eliminates the necessity for splice hangers and ensures a smooth continuous track.

Splice Clamp V8624 aligns the sides and track tread and holds the two track sections in position for welding.

### Splice Hanger Assembly V8671

#### Bolted Splice Connection

Weight: 5 lb



Splice Hanger Assembly V8671 securely clamps and holds the joined section of track in alignment. Two heavy cast wedges with serrated edges are drawn together by bolts through the sides of the bracket. When the wedges are tightened, the serrations tightly grip the track and clamp the track ends securely together. This assembly is also used as a suspension bracket. **(Power only use,)**

## Track Accessories

### Inspection Gate V20502

Weight: 12 lb

This removable track section is designed to simplify inspection and maintenance of the conveyor chain. It should never be opened while the conveyor is in operation.

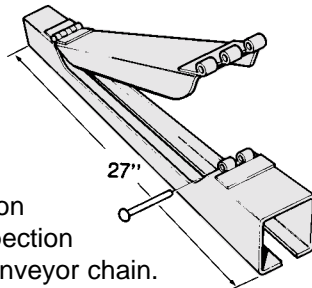

### Installation Gate V17095

Weight: 12 lb

At least one installation gate is required on every conveyor and is normally located at the exit end of the drive. It should never be opened while the conveyor is in operation.

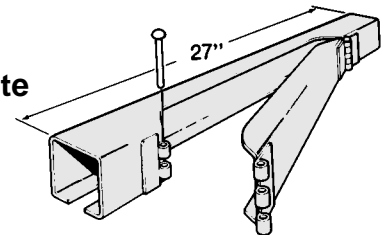

### Building and Oven Expansion Joints V20143

Weight: 12 lb

This expansion joint should be used to compensate for track expansion caused by heat, for any conveyor passing through an oven. Also, this expansion joint should be installed in line with all building expansion joints.

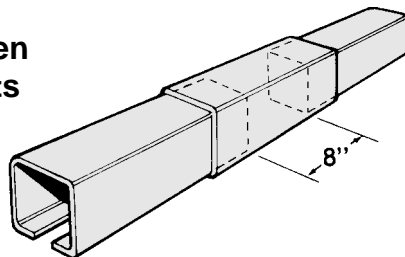

### Take-Up Expansion Joint V20144

Weight: 20 lb

This expansion joint is for use on those occasions when you have a field-erected take-up (23" closed-31" open).

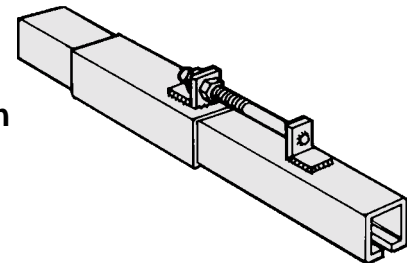

## Standard Turns and Curves

All horizontal turns are available in 24" and 36" radii and vertical curves illustrated are carried in stock for immediate delivery. However, special radius and/or degree turns can be fabricated upon request. For smaller than 24" radius, horizontal traction wheels can be furnished.

Both horizontal turns and vertical curves are formed from V20200 track. Those of 24" and 36" radii are heat-treated in areas of wheel contact to ensure a hard, tough surface for added anti-wear qualities.

Standard turns are fabricated with 8 inches of straight track on each end. However, special turns can be fabricated to order with less for areas where turn tangents are closer than 16 inches.

### Horizontal Turns

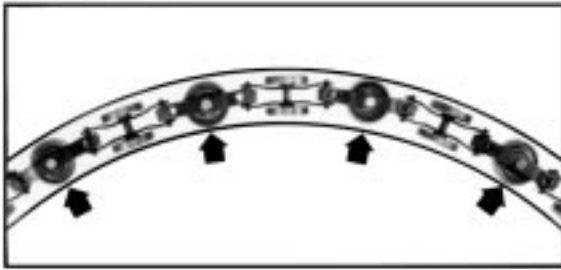

Horizontal turn with top removed illustrates how the chain passes around the curve. The lateral wheels ride on the side of the track, which guides the chain smoothly around a horizontal turn without the use of special guides, traction wheels or roller turns.

### Vertical Curves

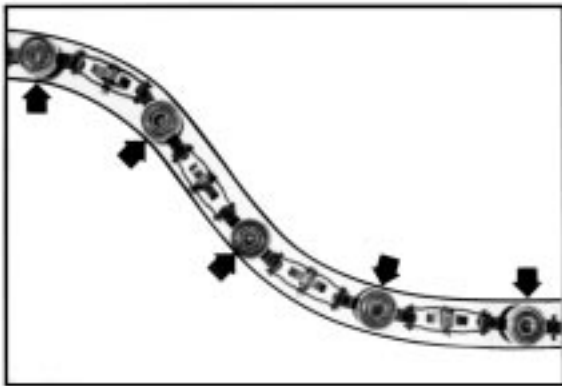

Compound Vertical curve with one side removed illustrates how the vertical chain wheels contact the top of the lower curve and the bottom of the upper curve.

For inverted applications, it is suggested that only inverted horizontal turns be used.

### Inverted Horizontal Turns

Part No.	Description	Weight
V21495	24" R x 30°	11 lb
V21496	24" R x 45°	13 lb
V21497	24" R x 60°	16 lb
V21498	24" R x 90°	21 lb
V21506	24" R x 180°	35 lb
V21499	36" R x 30°	13 lb
V21500	36" R x 45°	17 lb
V21501	36" R x 60°	21 lb
V21502	36" R x 90°	28 lb
V21503	36" R x 180°	49 lb

### Overhead Horizontal Turns

Part No.	Description	Weight
V20076	24" R x 30°	11 lb
V20077	24" R x 45°	13 lb
V20078	24" R x 60°	16 lb
V20079	24" R x 90°	21 lb
V20080	24" R x 180°	35 lb
V20081	36" R x 30°	13 lb
V20082	36" R x 45°	17 lb
V20083	36" R x 60°	21 lb
V20084	36" R x 90°	28 lb
V20085	36" R x 180°	49 lb
V20087	48" R x 90°	40 lb

30°  
Horizontal  
Turn

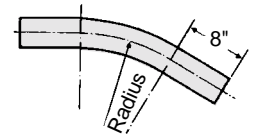

45°  
Horizontal  
Turn

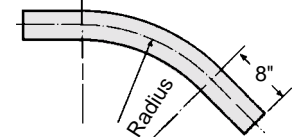

90°  
Horizontal  
Turn

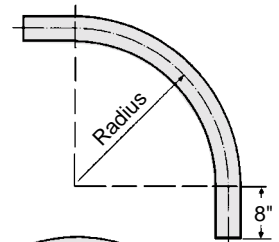

180°  
Horizontal  
Turn

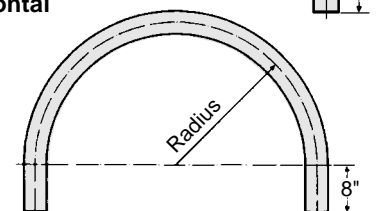

## Vertical Curve Charts

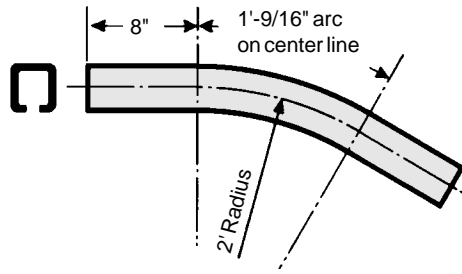
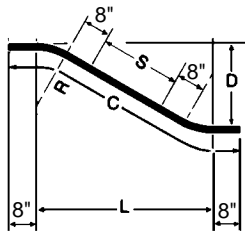

**2'-0" RAD. 30°  
Lower Vertical Curve V20112**

Weight: 10.8 lb

**2'-0" RAD. 30°  
Upper Vertical Curve V20111**

Weight: 10.8 lb

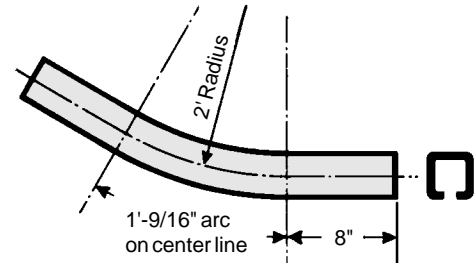

### 2'0" Radius X 30 Degrees

Drop	S	L	C
1'-2-3/8"	0	3'-1-7/8"	4'-9-1/8"
1'-6"	0'-7-1/8"	3'-8"	5'-4-1/4"
1'-9"	1'-1-1/8"	4'-1-1/4"	5'-10-1/4"
2'-0"	1'-7-1/8"	4'-6-3/8"	6'-4-1/4"
2'-3"	2'-1-1/8"	4'-11-5/8"	6'-10-1/4"
2'-6"	2'-7-1/8"	5'-4-7/8"	7'-4-1/4"
2'-9"	3'-1-1/8"	5'-10"	7'-10-1/4"
3'-0"	3'-7-1/8"	6'-3-1/4"	8'-4-1/4"
3'-6"	4'-7-1/8"	7'-1-5/8"	9'-4-1/4"
4'-0"	5'-7-1/8"	8'-0"	10'-4-1/4"
4'-6"	6'-7-1/8"	8'-10-3/8"	11'-4-1/4"
5'-0"	7'-7-1/8"	9'-8-3/4"	12'-4-1/4"
5'-6"	8'-7-1/8"	10'-7-1/8"	13'-4-1/4"
6'-0"	9'-7-1/8"	11'-5-5/8"	14'-4-1/4"
6'-6"	10'-7-1/8"	12'-4"	15'-4-1/4"
7'-0"	11'-7-1/8"	13'-2-3/8"	16'-4-1/4"
7'-6"	12'-7-1/8"	14'-0-3/4"	17'-4-1/4"
8'-0"	13'-7-1/8"	14'-11-1/8"	18'-4-1/4"
8'-6"	14'-7-1/8"	15'-9-1/2"	19'-4-1/4"
9'-0"	15'-7-1/8"	16'-7-7/8"	20'-4-1/4"
9'-6"	16'-7-1/8"	17'-6-3/8"	21'-4-1/4"
10'-0"	17'-7-1/8"	18'-4-3/4"	22'-4-1/4"
10'-6"	18'-7-1/8"	19'-3-1/8"	23'-4-1/4"
11'-0"	19'-7-1/8"	20'-1-1/2"	24'-4-1/4"
11'-6"	20'-7-1/8"	20'-11-7/8"	25'-4-1/4"
12'-0"	21'-7-1/8"	21'-10-1/4"	26'-4-1/4"
12'-6"	22'-7-1/8"	22'-8-5/8"	27'-4-1/4"

### 3'0" Radius X 30 Degrees

Drop	S	L	C
1'-5-5/8"	0	4'-1-7/8"	5'-9-3/4"
1'-9"	0'-6-3/4"	4'-7-5/8"	6'-4-3/8"
2'-0"	1'-0-3/4"	5'-0-7/8"	6'-10-3/8"
2'-3"	1'-6-3/4"	5'-6"	7'-4"
2'-6"	2'-0-3/4"	5'-11-1/4"	7'-10-3/8"
2'-9"	2'-6-3/4"	6'-4-1/2"	8'-4-3/8"
3'-0"	3'-0-3/4"	6'-9-5/8"	8'-10-3/8"
3'-6"	4'-0-3/4"	7'-8"	9'-10-3/8"
4'-0"	5'-0-3/4"	8'-6-3/8"	10'-10-3/8"
4'-6"	6'-0-3/4"	9'-4-7/8"	11'-10-3/8"
5'-0"	7'-0-3/4"	10'-3-1/4"	12'-10-3/8"
5'-6"	8'-0-3/4"	11'-1-5/8"	13'-10-3/8"
6'-0"	9'-0-3/4"	12'-0"	14'-10-3/8"
6'-6"	10'-0-3/4"	12'-10-3/8"	15'-10-3/8"
7'-0"	11'-0-3/4"	13'-8-3/4"	16'-10-3/8"
7'-6"	12'-0-3/4"	14'-7-1/8"	17'-10-3/8"
8'-0"	13'-0-3/4"	15'-5-5/8"	18'-10-3/8"
8'-6"	14'-0-3/4"	16'-4"	19'-10-3/8"
9'-0"	15'-0-3/4"	17'-2-3/8"	20'-10-3/8"
9'-6"	16'-0-3/4"	18'-0-3/4"	21'-10-3/8"
10'-0"	17'-0-3/4"	18'-11-1/8"	22'-10-3/8"
10'-6"	18'-0-3/4"	19'-9-1/2"	23'-10-3/8"
11'-0"	19'-0-3/4"	20'-7-7/8"	24'-10-3/8"
11'-6"	20'-0-3/4"	21'-6-3/8"	25'-10-3/8"
12'-0"	21'-0-3/4"	22'-4-3/4"	26'-10-3/8"
12'-6"	22'-0-3/4"	23'-3-1/8"	27'-10-3/8"

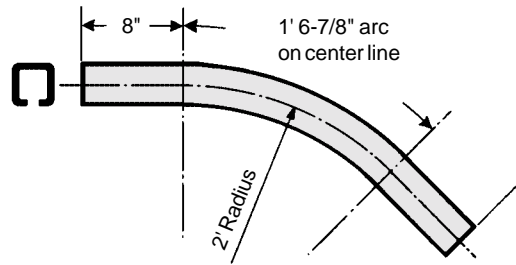

**2'-0" RAD. 45°  
Lower Vertical Curve V20114**

Weight: 13.1 lb

**2'-0" RAD. 45°  
Upper Vertical Curve V20113**

Weight: 13.1 lb

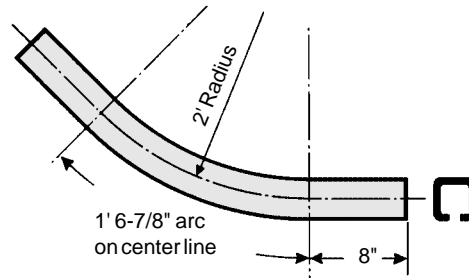
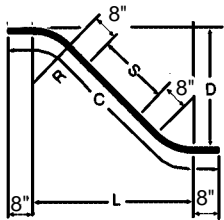

**2'0" Radius X 45 Degrees**

Drop	S	L	C
2'-3"	0'-2-1/4"	3'-10-7/8"	6'-0"
2'-6"	0'-6-1/2"	4'-1-7/8"	6'-4-1/4"
2'-9"	0'-10-3/4"	4'-4-7/8"	6'-8-1/2"
3'-0"	1'-3"	4'-7-7/8"	7'-0-3/4"
3'-6"	1'-11-1/2"	5'-1-7/8"	7'-9-1/4"
4'-0"	2'-8"	5'-7-7/8"	8'-5-3/4"
4'-6"	3'-4-1/2"	6'-1-7/8"	9'-2-1/8"
5'-0"	4'-1"	6'-7-7/8"	9'-10-5/8"
5'-6"	4'-9-1/2"	7'-1-7/8"	10'-7-1/8"
6'-0"	5'-6"	7'-7-7/8"	11'-3-5/8"
6'-6"	6'-2-3/8"	8'-1-7/8"	12'-0-1/8"
7'-0"	6'-10-7/8"	8'-7-7/8"	12'-8-5/8"
7'-6"	7'-7-3/8"	9'-1-7/8"	13'-5-1/8"
8'-0"	8'-3-7/8"	9'-7-7/8"	14'-1-5/8"
8'-6"	9'-0-3/8"	10'-1-7/8"	14'-10-1/8"
9'-0"	9'-8-7/8"	10'-7-7/8"	15'-6-1/2"
9'-6"	10'-5-3/8"	11'-1-7/8"	16'-3"
10'-0"	11'-1-7/8"	11'-7-7/8"	16'-11-1/2"
10'-6"	11'-10-1/4"	12'-1-7/8"	17'-8"
11'-0"	12'-6-3/4"	12'-7-7/8"	18'-4-1/2"
11'-6"	13'-3-1/4"	13'-1-7/8"	19'-1"
12'-0"	13'-11-3/4"	13'-7-7/8"	19'-9-1/2"
12'-6"	14'-8-1/4"	14'-1-7/8"	20'-6"

Min. Drop is 2'-1-3/8" when S = 0

L = 3'-9-1/4"  
C = 5'-9-3/4"

**3'0" Radius X 45 Degrees**

Drop	S	L	C
3'-0"	0'-5-1/8"	5'-5-7/8"	7'-9-5/8"
3'-6"	1'-1-5/8"	5'-11-7/8"	8'-6-1/8"
4'-0"	1'-10"	6'-5-7/8"	9'-2-5/8"
4'-6"	2'-6-1/2"	6'-11-7/8"	9'-11-1/8"
5'-0"	3'-3"	7'-5-7/8"	10'-7-5/8"
5'-6"	3'-11-1/2"	7'-11-7/8"	11'-4-1/8"
6'-0"	4'-8"	8'-5-7/8"	12'-0-1/2"
6'-6"	5'-4-1/2"	8'-11-7/8"	12'-9"
7'-0"	6'-1"	9'-5-7/8"	13'-5-1/2"
7'-6"	6'-9-1/2"	9'-11-7/8"	14'-2"
8'-0"	7'-6"	10'-5-7/8"	14'-10-1/2"
8'-6"	8'-2-3/8"	10'-11-7/8"	15'-7"
9'-0"	8'-10-7/8"	11'-5-7/8"	16'-3-1/2"
9'-6"	9'-7-3/8"	11'-11-7/8"	17'-0"
10'-0"	10'-3-7/8"	12'-5-7/8"	17'-8-3/8"
10'-6"	11'-0-3/8"	12'-11-7/8"	18'-4-7/8"
11'-0"	11'-8-7/8"	13'-5-7/8"	19'-1-3/8"
11'-6"	12'-5-3/8"	13'-11-7/8"	19'-9-7/8"
12'-0"	13'-1-7/8"	14'-5-7/8"	20'-6-3/8"
12'-6"	13'-10-1/4"	14'-11-7/8"	21'-2-7/8"

Min. Drop is 2'-8-3/8" when S = 0

L = 5'-2-1/4"  
C = 7'-4-1/2"

**2'-0" RAD. 60°  
Upper Vertical Curve V20115**

Weight: 15.4 lb

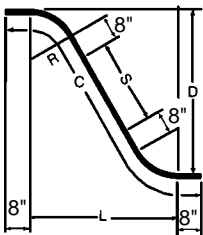
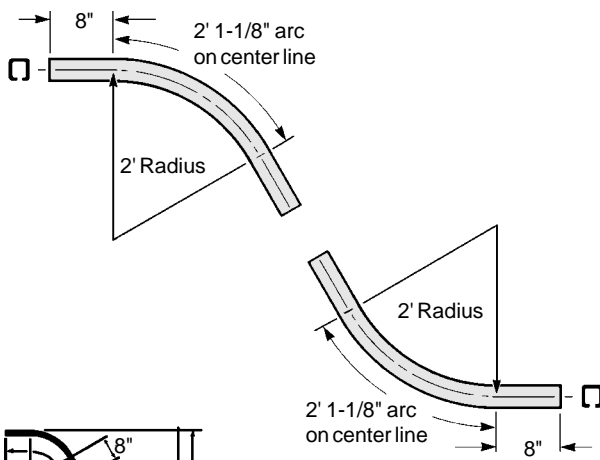

**2'-0" RAD. 90°  
Upper Vertical Curve V20117**

Weight: 20.1 lb

**2'-0" RAD. 60°  
Lower Vertical Curve V20116**

Weight: 15.4 lb

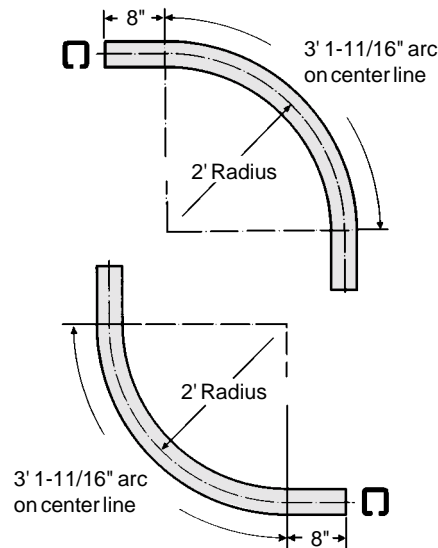

**2'-0" RAD. 90°  
Lower Vertical Curve V20118**

Weight: 20.1 lb

**2'0" Radius X 60 Degrees**

**3'0" Radius X 60 Degrees**

Drop	S	L	C
3'-6"	0'-4-3/4"	4'-4"	7'-3"
4'-0"	0'-11-3/4"	4'-7-3/8"	7'-10"
4'-6"	1'-6-5/8"	4'-10-7/8"	8'-4-7/8"
5'-0"	2'-1-5/8"	5'-2-3/8"	8'-11-7/8"
5'-6"	2'-8-1/2"	5'-5-7/8"	9'-6-3/4"
6'-0"	3'-3-3/8"	5'-9-1/4"	10'-1-3/4"
6'-6"	3'-10-3/8"	6'-0-3/4"	10'-8-5/8"
7'-0"	4'-5-1/4"	6'-4-1/4"	11'-3-1/2"
7'-6"	5'-0-1/4"	6'-7-5/8"	11'-10-1/2"
8'-0"	5'-7-1/8"	6'-11-1/8"	12'-5-3/8"
8'-6"	6'-2-1/8"	7'-2-5/8"	13'-0-3/8"
9'-0"	6'-9"	7'-6-1/8"	13'-7-1/4"
9'-6"	7'-3-7/8"	7'-9-1/2"	14'-2-1/4"
10'-0"	7'-10-7/8"	8'-1"	14'-9-1/8"
10'-6"	8'-5-3/4"	8'-4-1/2"	15'-4"
11'-0"	9'-0-3/4"	8'-7-7/8"	15'-11"
11'-6"	9'-7-5/8"	8'-11-3/8"	16'-5-7/8"
12'-0"	10'-2-5/8"	9'-2-7/8"	17'-0-7/8"
12'-6"	10'-9-1/2"	9'-6-3/8"	17'-7-3/4"

Drop	S	L	C
4'-6"	0'-4-3/4"	6'-0-3/4"	9'-4-1/8"
5'-0"	0'-11-3/4"	6'-4-1/4"	9'-11-1/8"
5'-6"	1'-6-5/8"	6'-7-5/8"	10'-6"
6'-0"	2'-1-5/8"	6'-11-1/8"	11'-1"
6'-6"	2'-8-1/2"	7'-2-5/8"	11'-7-7/8"
7'-0"	3'-3-3/8"	7'-6-1/8"	12'-2-7/8"
7'-6"	3'-10-3/8"	7'-9-1/2"	12'-9-3/4"
8'-0"	4'-5-1/4"	8'-1"	13'-4-5/8"
8'-6"	5'-0-1/4"	8'-4-1/2"	13'-11-5/8"
9'-0"	5'-7-1/8"	8'-7-7/8"	14'-6-1/2"
9'-6"	6'-2-1/8"	8'-11-3/8"	15'-1-1/2"
10'-0"	6'-9"	9'-2-7/8"	15'-8-3/8"
10'-6"	7'-3-7/8"	9'-6-3/8"	16'-3-3/8"
11'-0"	7'-10-7/8"	9'-9-3/4"	16'-10-1/4"
11'-6"	8'-5-3/4"	10'-1-1/4"	17'-5-1/8"
12'-0"	9'-0-3/4"	10'-4-3/4"	18'-0-1/8"
12'-6"	9'-7-5/8"	10'-8-1/8"	18'-7"

Min. Drop is 3'-1-7/8" when S = 0

L = 4'-1-5/8"  
C = 6'-10-1/4"

Min. Drop is 4'-1-7/8" when S = 0

L = 5'-10-3/8"  
C = 8'-11-3/8"

## Traction Wheel

Traction wheels must be used in place of horizontal turns when the radius is less than 24". Traction wheels are available with anti-friction bearings in pitch diameters (PD) of:

18" PD V20281    24" PD V20285  
30" PD V20289    36" PD V20293

Graphalloy bushings for oven applications (oven temperatures over 250°) are also available in pitch diameters of:

18" PD V20282    24" PD V20286  
30" PD V20290    36" PD V20294

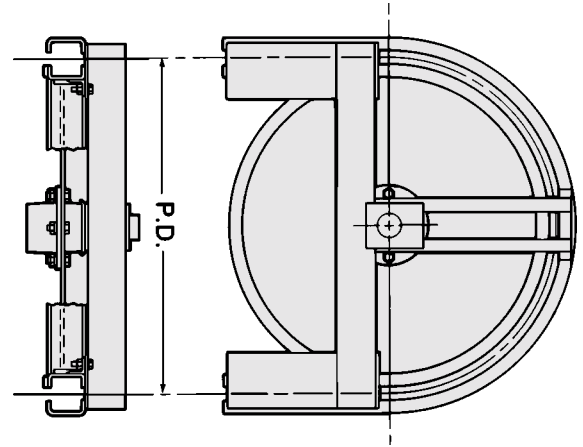

Weight: 150 lb

## Safety Stops

### Anti-Backup Safety Stop V9012

The Unibilt Anti-Backup Safety Stop V9012 consists of a heavy pawl pivoted on a shaft, which lifts out of the chain as the chain travels up a vertical incline. If the chain should break and attempt to reverse direction down the incline, the Anti-Backup Safety Stop will stop the chain and hold it securely.

Anti-Backup Safety Stops cannot be used where the chain is traveling down a vertical curve or on reversing conveyors.

**Note: On 90° inclines, special modifications must be incorporated. Consult a Unibilt Representative.**

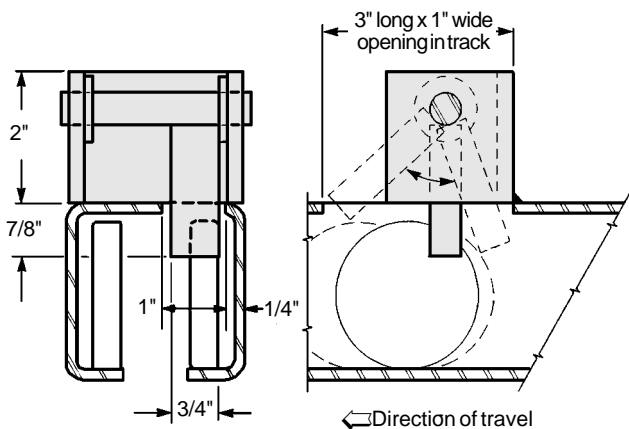

Weight: 1.5 lb

### Anti-Runaway Safety Stop V20206

Anti-Runaway Safety Stops are used as a precaution against possible chain breakage, the same as the Anti-Backup Safety Stop V9012, except they are utilized on vertical curves where the chain travels down.

The Unibilt Anti-Runaway is an inertia-operated device that is positive in operation and equipped with a limit switch to stop the drive when actuated. Maximum decline is 60 degrees.

It can be adjusted in the field to operate only when the chain accelerates beyond its normal maximum speed, which indicates a broken or runaway chain.

The Anti-Runaway Safety Stop is installed in the same position on a vertical curve as the Anti-Backup and can be used on vertical curves with the chain running in either direction and on reversing conveyors.

**Note: On 90 degree declines, special modifications must be incorporated. Consult a Unibilt representative.**

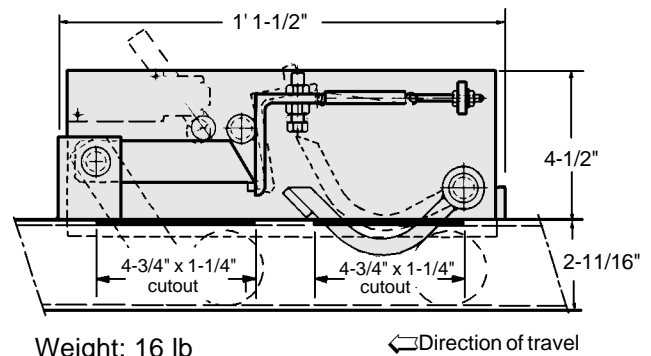

Weight: 16 lb

**Note: V9012 and V20206 are used in areas where a runaway chain would be hazardous. It is general practice to use one safety stop on vertical curves of 5'-0\"/>**

## Caterpillar Drive Units

### Caterpillar Drive Unit 600# Chain Pull Capacity



Weight: 375 lb

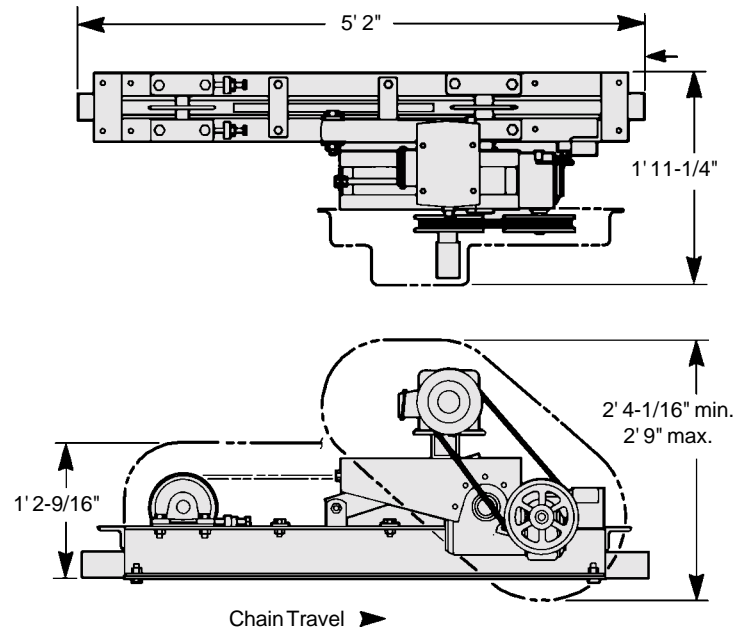

**Standard drives shown without guards are for illustration purposes only. Guards must always be in place before operating equipment.**

The Unibilt caterpillar drive unit is designed to provide maximum flexibility for all enclosed track power requirements in a single compact package. **Inverted drives are available upon request.**

**Many outstanding features make this drive unique in its class.**

- The drive has a 600 lb chain pull.
- Constant speed or variable speed available from stock. **Right handed drives are standard.**
- Variable speed drive units are equipped with a Vari-speed pulley providing a 3-to-1 speed range.
- Speed ranges from .6 FPM to 64.2 FPM in a ratio of 3-to-1 are available using stock parts and reducer ratios.
- Guards on drive units comply with applicable OSHA and ANSI B20.1 standards.
- The drive has an electrical automatic overload cut-off device, which is factory adjusted at 750 lb to stop the motor automatically when an overload or jam condition occurs.
- Multiple drives are required when chain pulls exceed 600 lb. Consult your Webb Regional Manager for multiple drive situations.
- Solid fixed heat-treated steel caterpillar driving dogs eliminate the need for special cams or springs to engage the conveyor chain.
- 1800 RPM, 230/460 volt, 3 phase, 60 hertz, TEFC motors are supplied unless otherwise specified.
- Motor controls (push buttons, starters, thermal overloads, etc.) are not included with drives, but can be supplied to your specifications.
- Drives are available with up to 10-to-1 speed variation, with AC or DC power supplies when remote control electrical speed variation and balancing is desired.
- Drive chain and beltguards are standard and supplied with each drive.
- Four 9/16"-diameter holes are provided, one at each corner as illustrated, for convenient hanging. Drive units should be braced adequately to eliminate vibration. Refer to installation methods for hanging and bracing technique.
- Unibilt caterpillar drives permit positioning the drive at the most advantageous location on the system, rather than confining drive location to a horizontal turn, as necessary when driving with a sprocket drive.
- Drive frame and track are painted Unibilt Blue.

## Caterpillar Drive Unit 300# Chain Pull Capacity



Weight: 300 lb

- Caterpillar drive unit with 300# chain pull capacity. Speeds from 1.0 to 40 FPM available with standard 1/2 H.P. motor. Other speeds available with special motors and reducers. **Left handed drives are standard.**
- Constant speed and variable speed available.
- Includes 1/2 H.P. 1725 R.P.M., 230/460 volt, 3 phase, 60 hertz, TEFC motor, and a combination chain and belt guard.

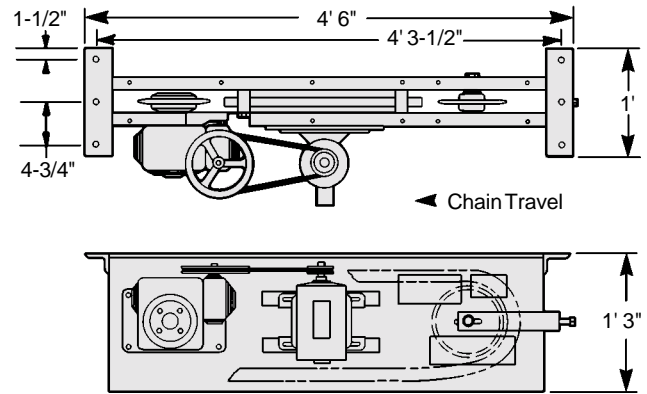

- The drive uses an overload torque limiter built into the hub of the caterpillar chain drive sprocket. It is set at 450 lbs.
- A belt and chain guard is standard and supplied with each drive.
- Uses same caterpillar drive chain as standard 600# capacity drive unit.
- Motor controls (push button, starters, thermal over loads, etc.) are not included.
- AC or DC motors for variable speed at 10-to-1 speed variation available upon request.

## Chain Take-ups

### Spring Take-up V20149

A chain take-up is necessary in every Unibilt Enclosed Track system to remove any slack chain that may accumulate in the system. It compensates for chain growth for most temperature changes that would expand or contract the chain and relieves chain tension to uncouple the chain. Take-ups are available in several styles, however, spring, counterweight, and air are most common.

- The spring take-up V20149 is used for normal conveyor conditions where no temperature extremes are encountered.

**Counterweight Take-up V20148**  
**Air Cylinder Operated V20147**

The counterweight take-up and air cylinder operated are used when automatic slack chain removal is necessary, generally where oven temperatures elongate the chain during production hours and then cool and contract the chain during off hours.

- All styles of take-ups are self-contained and mounted on a rigid frame, which eliminates binding or twisting and requires no fabricating or welding in the field.

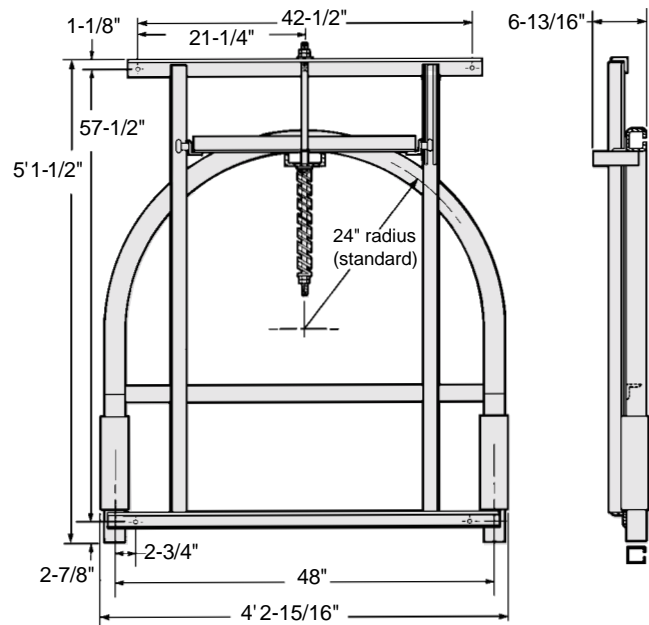

Weight: 146 lb

Standard radius is 2'-0"; however, smaller radii are available with the use of traction wheels. The standard spread is 4'-0" and a recommended maximum is 10'-0". This dimension should be specified when ordering. Standard travel is 8" with 24" travel also available. The take-up is normally suspended by angle bracing welded or bolted to the frame. The 1/2" diameter rods may also be used to hang the unit.

## Chain Load Attachments

A number of load-carrying attachments have been developed to suspend a large variety of carriers and loads from the chain.

The standard attachments illustrated below are those that have the widest usage and are adaptable to almost every type of load. Special attachments can be designed to accommodate special applications.

### Standard "H" Attachment V21298

(Capacity 125 lb, Max. 45° Incline)

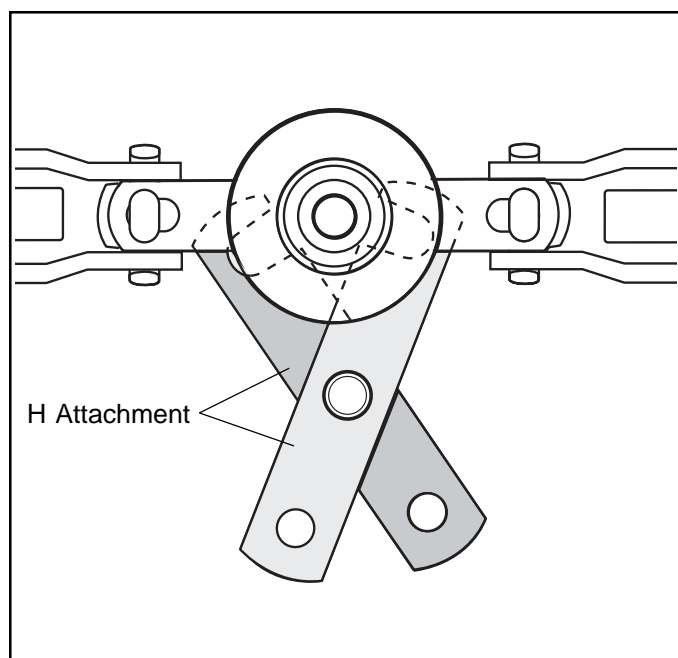

The Standard "H" Attachment is the most popular unit for connecting loads to the chain. It engages the load-wheel axle with a scissor like action. The illustrations show how the attachment grips the load-wheel axle and is locked in position by the load-carrying bolt in the bottom hole and cannot be removed until the bolt is removed.

### Rigid "H" Attachment V16975

(Capacity 75 lb)

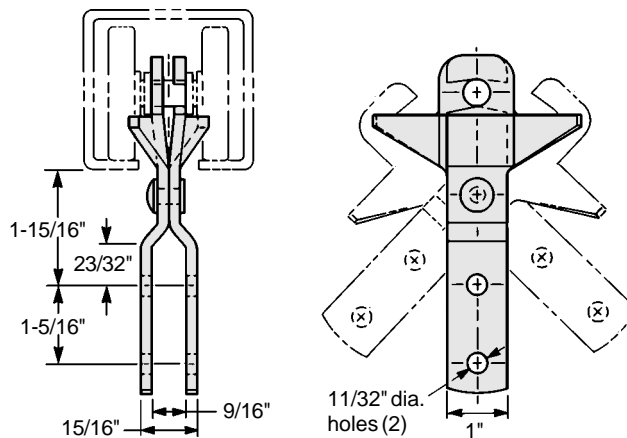

Similar to V21298 except this attachment remains perpendicular to the chain. There is also an extra attaching hole 3-1/4" below the bottom of the track. Capacity is 75 lb

### Load Bar Attachment V9032

Capacity:  
 250 lb, Level Systems  
 200 lb, Maximum Degree of Incline 30°  
 175 lb, Maximum Degree of Incline 45°

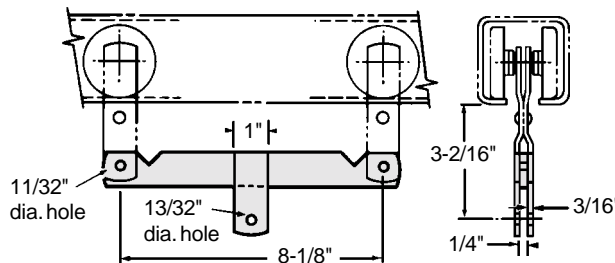

Load Bar Attachment V9032 is suspended from two "H" attachments, thereby increasing the capacity of the load carrier. ("H" attachments must be ordered separately.) 5/16" bolt or hardened rivet not included.

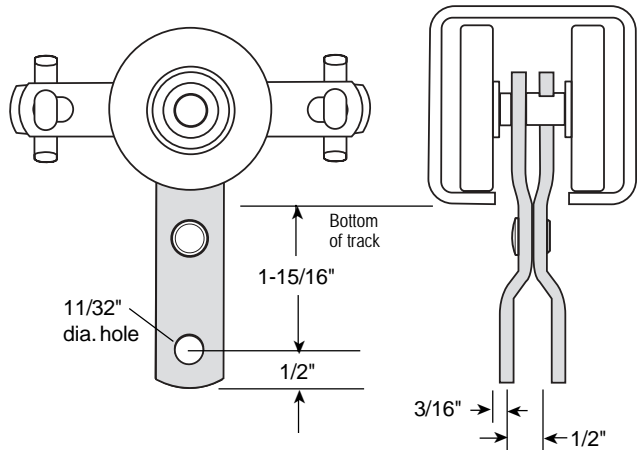

Weight: 0.5 lb

## Extended "H" Attachment V16984

(Capacity 125 lb)

Extended "H" Attachment V16984 is used to extend the carrier or load away from the track for additional clearance when traveling vertically.

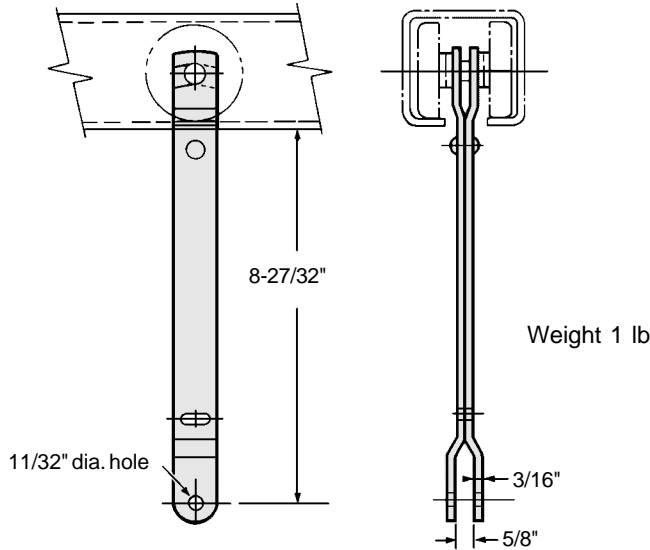

## Spinner Attachment V21517

(Capacity 65 lb, Maximum degree of incline 45°)

Spinner Attachment V21517 is used where continuous rotation of product is necessary through a wash or paint finishing operation. The ball bearing roller revolves against a flat bearing strip by the forward motion of the conveyor. Higher capacity units are available.

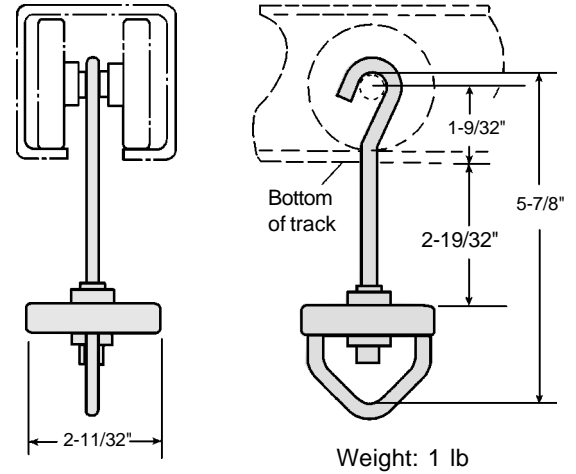

## Extended Rigid "H" Attachment

(Capacity 125 lb, Minimum radius 24")

V16988 8" Drop V16989 11" Drop

Extended Rigid "H" Attachment V16988 is used primarily on conveyors with vertical travel. This attachment holds the carrier or load away from the track when traveling vertically. The 8" offset is standard; however, special offsets can be fabricated to order.

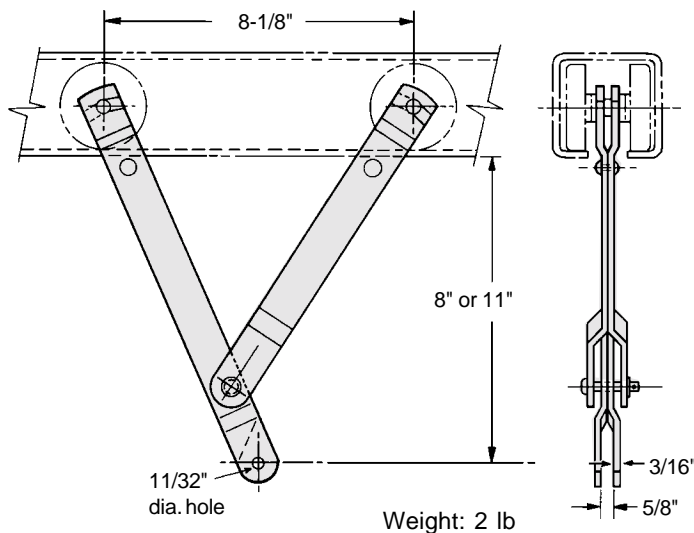

## 90 Degree Star Wheel Indexing Swivel Hook Assembly V8345

(Capacity 125 lb)

This 90° indexing swivel allows for carrier rotation in 90° increments with the use of a camming device. The swivel hook is made of malleable iron and is shipped loose in two (2) pieces; V16164 swivel & V6513 shank.

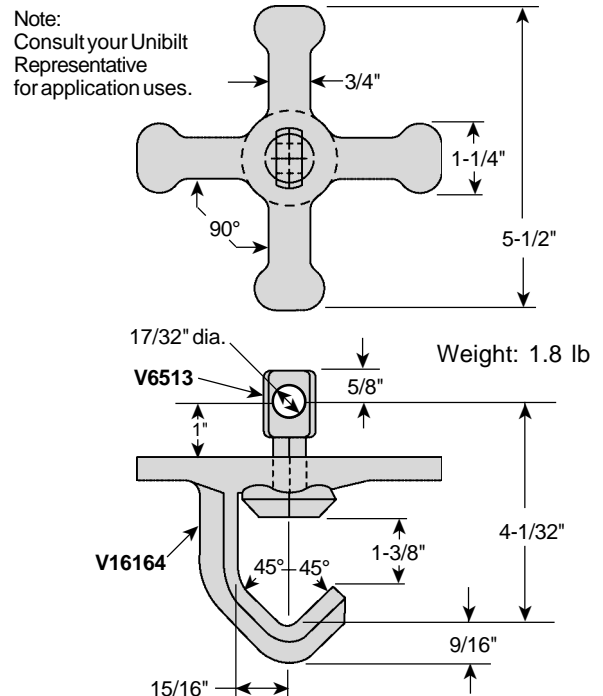

### 4 Wheel Chain Attachments V16949

These attachments are a heat-treated, high-strength, drop-forged steel that can be installed in the chain on nominal 8" centers as required. Use of this unit increases individual load capacity to 250 lb per unit.

Weight: 3.2 lb

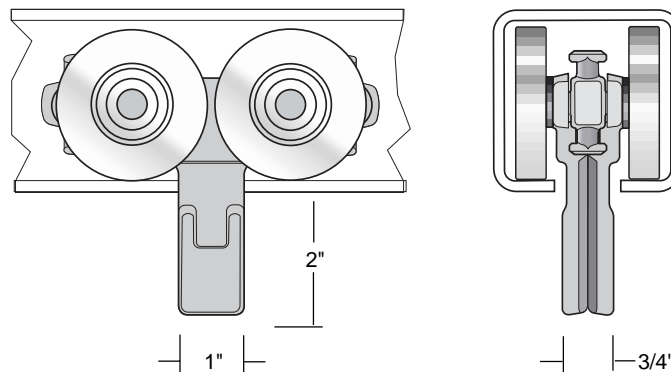

### 4 Wheel Chain Attachments V16971

These attachments have the same construction as V16949 but can have a **1/2" diameter shaft or bolt inserted in the frame**. Capacity is 250 lb

Weight: 1.5 lb

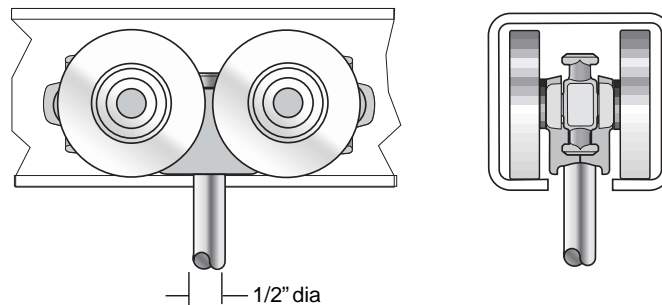

### 4 Wheel Chain Attachment V21064

These attachments have the same construction as V16949 and V16971 but include a **guide roller for stability when used in inverted applications**. 4 Wheel Capacity is 250 lb

4 Wheel Weight: 3.5 lb

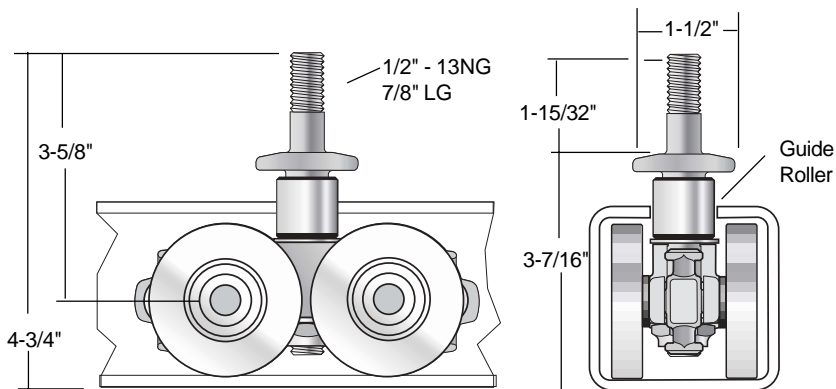

### Inverted Chain Attachment Assembly with Load Bar V21067

This assembly is used with a "C" hook application. Attachments have the same construction as V21064.

Weight: 10 lb

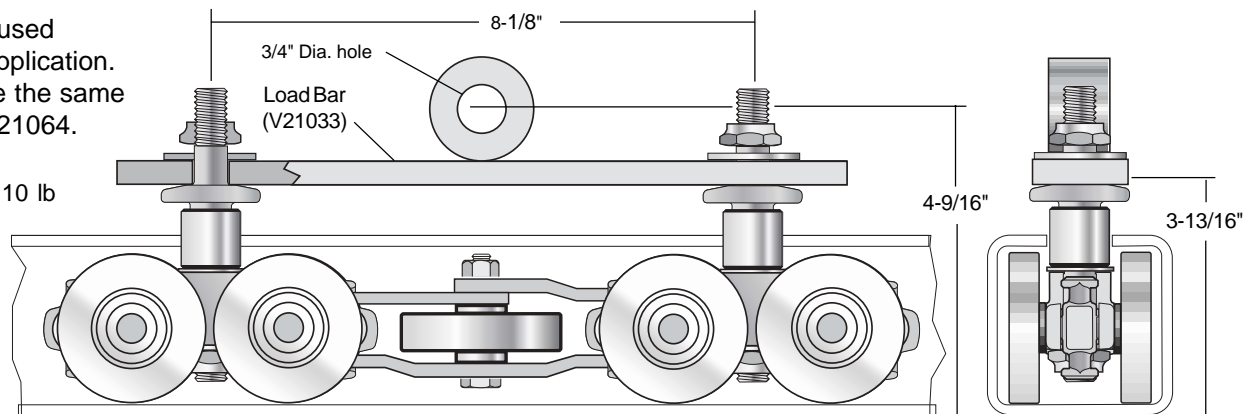

## Lubrication

### Brush-Type Chain Oiler V20053 and V20058

Unibilt chain lubricators provide oil lubrication to the guide and load wheel bearings and to each pivot in the chain assembly. The proper amount of lubricant can be regulated with an adjustable needle valve to assure adequate lubrication at each point without over-oiling and dripping. Proper lubrication is necessary to maintain the low friction of the conveyor system, decrease system wear and maintenance, and prolong the life of the system. Chain lubricator V20053 includes a one-quart transparent oil reservoir, a visual sight gauge for oil feed, and a manual On/Off Valve. Chain lubricator V20058 (illustrated) is the same as V20053, except that V20058 is equipped with an electric On/Off valve for remote control operation. It can be adjusted to operate automatically only when the conveyor is running. Both lubricators are shipped without a section of track. Slot is to be cut in the field.



**Note: Not recommended for use in paint finishing systems.**

Weight: 4 lb

### Automatic Chain Lubricator V21516WS With Timer

The Unibilt Conveyor Chain Lubricator provides fully automatic oil lubrication at any desired interval.

The nine lubricating nozzles are designed to accurately deliver metered amounts of lubricant directly to the load wheel and side guide wheel bearings and to the pivot points in the chain assembly. The single-impulse positive displacement metering pump provides the proper amount of lubricant to each lubrication point, eliminating over-oiling and possible product contamination.

The V21516WS automatic chain lubricator is recommended for use on conveyor systems with a high degree of contamination such as finishing systems with washers and ovens.

The V21516WS lubricator is provided complete with a 2'-0" long section of conveyor track. This eliminates the need for track modifications or special mounting in the field.



**Note: Not to be used with 4 wheel chain attachments.**

Weight: 50 lb

## Carriers

Illustrated are a variety of carrier styles that have been used in various industries. One might fit your particular needs. Your local Unibilt sales engineer is experienced in carrier design and is available for assistance or to completely engineer and fabricate special carriers that will enhance your conveyor operation.



## Suspension Fittings (Power Only Use)

### Hanger Bracket V8670

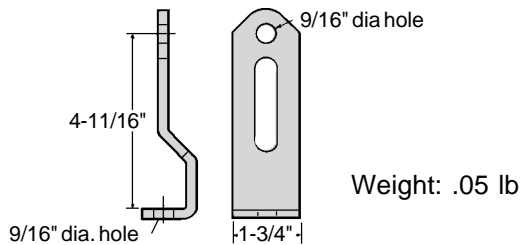

Hanger Bracket V8670 is used when connecting 1/2"-diameter threaded rod hanger to Channel Clamp V20270 and Beam Clamp Assembly V9016.

It provides a pivot point at the clamp so the hangers can be used at any angle, and also provides 3-1/2" of hanger adjustment for easy leveling of the conveyor track.

Maximum load capacity is 1000 lb

### Track Hanger Clamp V8672

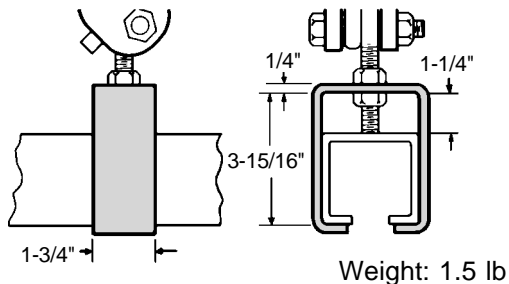

Hanger Clamp V8672 is used to suspend the conveyor track with 1/2"-diameter rod hangers when joints are welded at suspension points between bolted splice hanger assemblies.

Maximum load capacity is 1000 lb

### Bracing Connector (Double) V8679

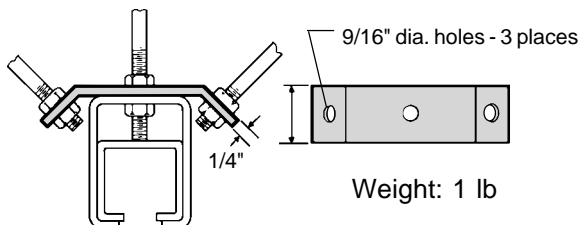

Bracing Connector V8679 can be used for sway-bracing in two directions or for supporting the track with a diagonal hanger.

Maximum load capacity is 1000 lb

### Bracing Connector (Single) V9000

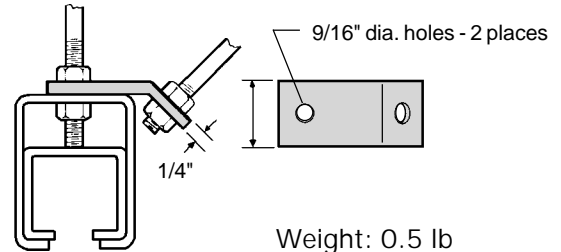

Bracing Connector V9000 is utilized when threaded 1/2" diameter rod is used for sway-bracing.

This connector can be used with Splice Hanger Assembly V8671 or Hanger Clamp V8672.

### 1/2" Threaded Rod V18276



Threaded rod is furnished 12'0" long, with 1/2-13 NC thread. The exact length of hanger rods is often difficult to determine; therefore, it is recommended they be ordered 12'0" long and cut to proper length when the conveyor is erected.

Special 1/2" rod hangers can be furnished up to 20'0" long, cut on order to any length, and threaded 12" on each end.

Maximum load capacity is 1000 lb

**Note: All load capacities stated are dependent upon the total building capacity. We recommend you contact a plant engineer or architect to determine your individual requirements.**

## *Over-N-Under<sup>®</sup> Conveyors*

### **Gravity Flow Over-N-Unders**

Gravity Flow Over-N-Unders rely on product weight and pitching of the Over-N-Under for parts forwarding. The high end of the conveyor is the load end and the low end is the unload end. Unloading parts creates an unbalanced load across the chain, which causes the remaining parts to flow forward. As the load travels down the lower rail, the empty hooks automatically return over the top rail.

### **Tandem Over-N-Unders**

Tandem Over-N-Unders are powered by modified Unibilt drives which keep the chain in synchronized adjacent loops. Tandem Over-N-Under conveyors are used when increased stability is needed due to wide production load and in applications where load capacities are substantially higher.

### **Powered Over-N-Unders**

Powered Over-N-Unders utilize a Unibilt drive to move parts from load to unload and are not restricted to straight loop designs. Horizontal turns and vertical curves can be incorporated to bypass aisles and other obstacles.

### **Power & Free Over-N-Unders**

Power & Free Over-N-Unders provide a cost effective solution to storage and accumulation problems. The closed loop configuration assures adequate empty carrier storage on the upper section of the loop, while maintaining a "keep full" carrier situation on the lower section. The Power and Free concept utilizes two tracks: one that houses the power chain and one that houses the free trolleys. Free trolleys are moved through the system by a patented pusher dog attached to a single power chain.

***Gravity Flow  
Over-N-Under  
Conveyor,  
an inexpensive  
solution to  
storage and  
accumulation  
problems.***



**Tandem  
Over-N-Under  
Conveyor,**  
*production  
flexibility, to move  
wider and heavier  
loads efficiently.*



**Powered  
Over-N-Under  
Conveyor,**  
*design flexibility,  
a cost-effective way  
to move parts over  
aisles and  
obstacles.*



**Power & Free  
Over-N-Under  
Conveyor,**  
*system flexibility, for  
independent loading  
and unloading  
without interrupting  
production flow.*



## Hand-Pushed Trolley

### Hand-Pushed Trolley V20105

(Capacity 250 lbs.)

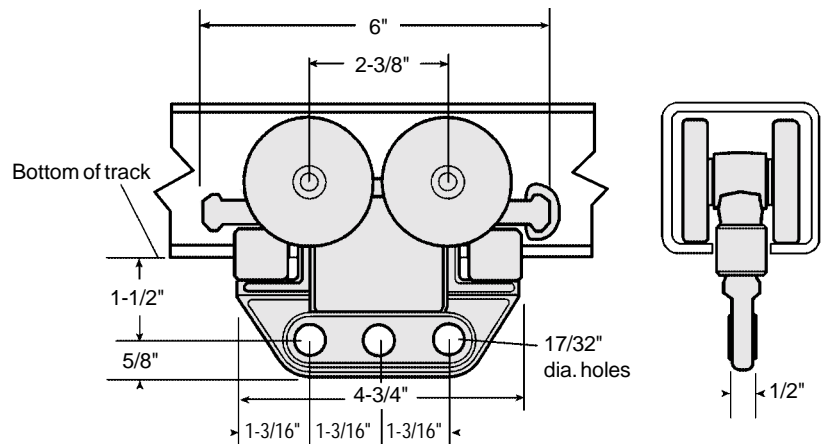

Weight: 6.3 lb

This is our most economical four-wheel hand-pushed trolley.

- Load capacity is 250 pounds per trolley. Load capacity of four trolleys connected in tandem with load bars is 1000 pounds.
- The unique side guide rollers originated and patented by the Jervis B. Webb Company are the secret that keeps Unibilt hand-pushed trolleys rolling smoothly. The bracket cannot rub against the flange of the track when negotiating horizontal curves.
- Rolling action prevents undue wear on the flange and offers greater ease in pushing loads. This feature also helps to eliminate sloppy side sway, reducing spillage.
- High-strength cast body provides a high degree of safety, even under heavy shock loading.
- 2-1/4" ball bearing wheels with hardened races and tread minimize pushing effort and prolong trolley life.

**Note: Trolley is also available with nylon wheels and nylon side guide rollers.**

- Hardened side guide rollers with stainless steel guide roller pins help eliminate binding or freezing of rollers due to corrosion.
- Three-hole load connection mounts carriers rigidly to the trolleys, when necessary, to prevent excessive pendulum motion. Available with rubber bumpers.
- For hand-pushed trolleys with rubber bumpers order V16980.

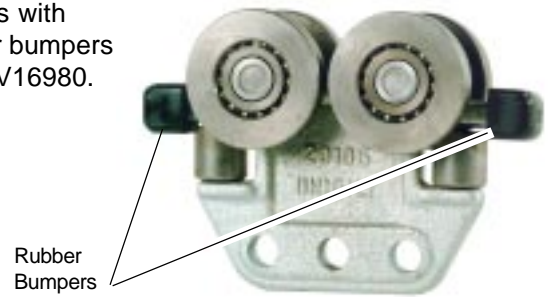

## Deep Track

### Deep Track V20202

The 4-1/2" depth and one-piece construction of Deep Track makes it stronger than conventional free track, requiring fewer supports over long spans.

Deep track can be used in conjunction with Stop-N-Flow conveyors. When the power track is not used, such as in storage spurs, it replaces the conventional free track. Consult your Webb Regional Manager for details.

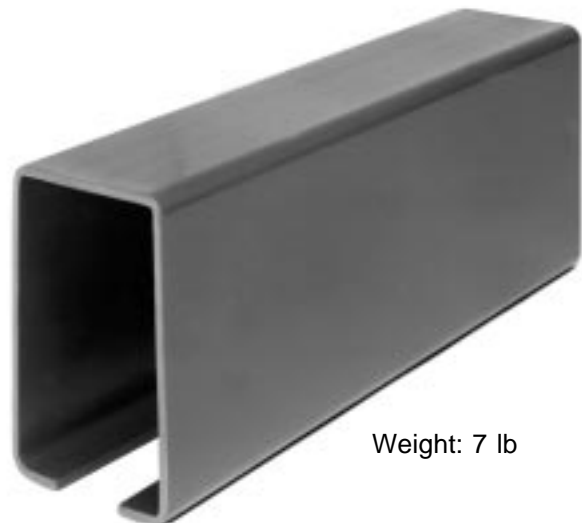

Weight: 7 lb

## Hand Pushed Monorail

The Unibilt hand-pushed monorail is ideally suited to all types of manually operated monorail systems.

It has all the inherent advantages of an enclosed track and utilizes the same Unibilt overhead conveyor track and installation components.

The following equipment is available to suit every system from the simplest to the most complex:

- Stops, manual and automatic
- Switches, manual and automatic
- Turntables (V9067)
- Automatic lifts for multi-level operation

*Shown here is a Unibilt Deep Track in-process storage spur. Multiple storage of parts on a diagonal yields greater utilization of storage space.*



## Typical Hand-Pushed Layout

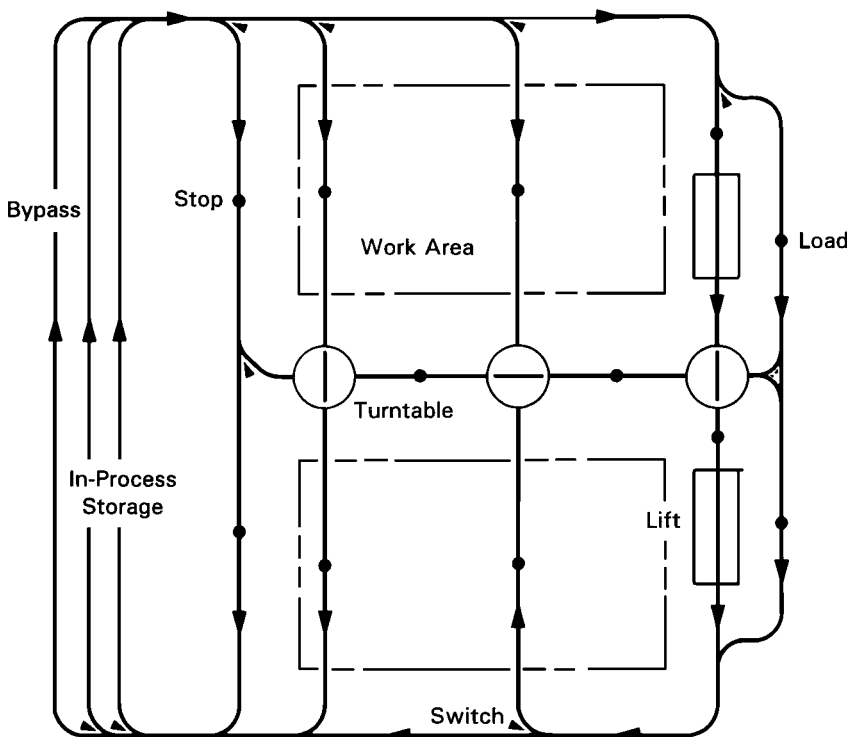

**Frog Switch LH-V65526 (shown)  
RH-V65527**

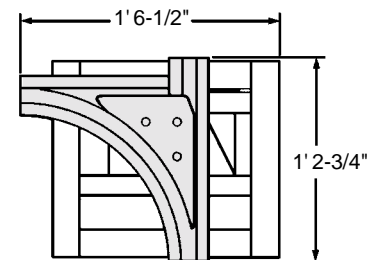

**Universal Switch LH-V65528 (shown)  
RH-V65529**

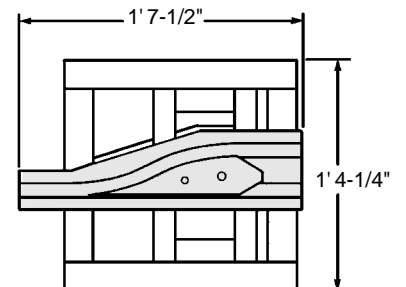

## Stop-N-Flow<sup>®</sup> Power & Free Conveyors

Unibilt's Stop-N-Flow power & free conveyor, from the Jervis B. Webb Company, provides 100% positive mechanical load control over every carrier in a system at all times. This positive control of carriers through switches, lift sections, and intra-conveyor transfers makes it completely adaptable to computer or PLC level control.

Unlike a continuous-flow conveyor, power & free conveyors are not restricted by a moving chain. The retractable dog allows carriers to disengage from the power chain and stop, either individually or in groups, without interrupting the movement of other loads on the conveyor.

This allows many operations to be performed without shutting down the entire line. Webb's unique "Wide Wing<sup>™</sup>" design facilitates positive chain-to-chain transfers without the need for push-across transfers, paddle wheels or air cylinder pushers.

The flexibility of Unibilt power & free conveyors makes them ideal for routing carrier loads to multiple destinations. Lateral and vertical routing transfers are easy and inexpensive when compared to other methods. Unibilt power & free is the best choice for simple or complex conveying applications.

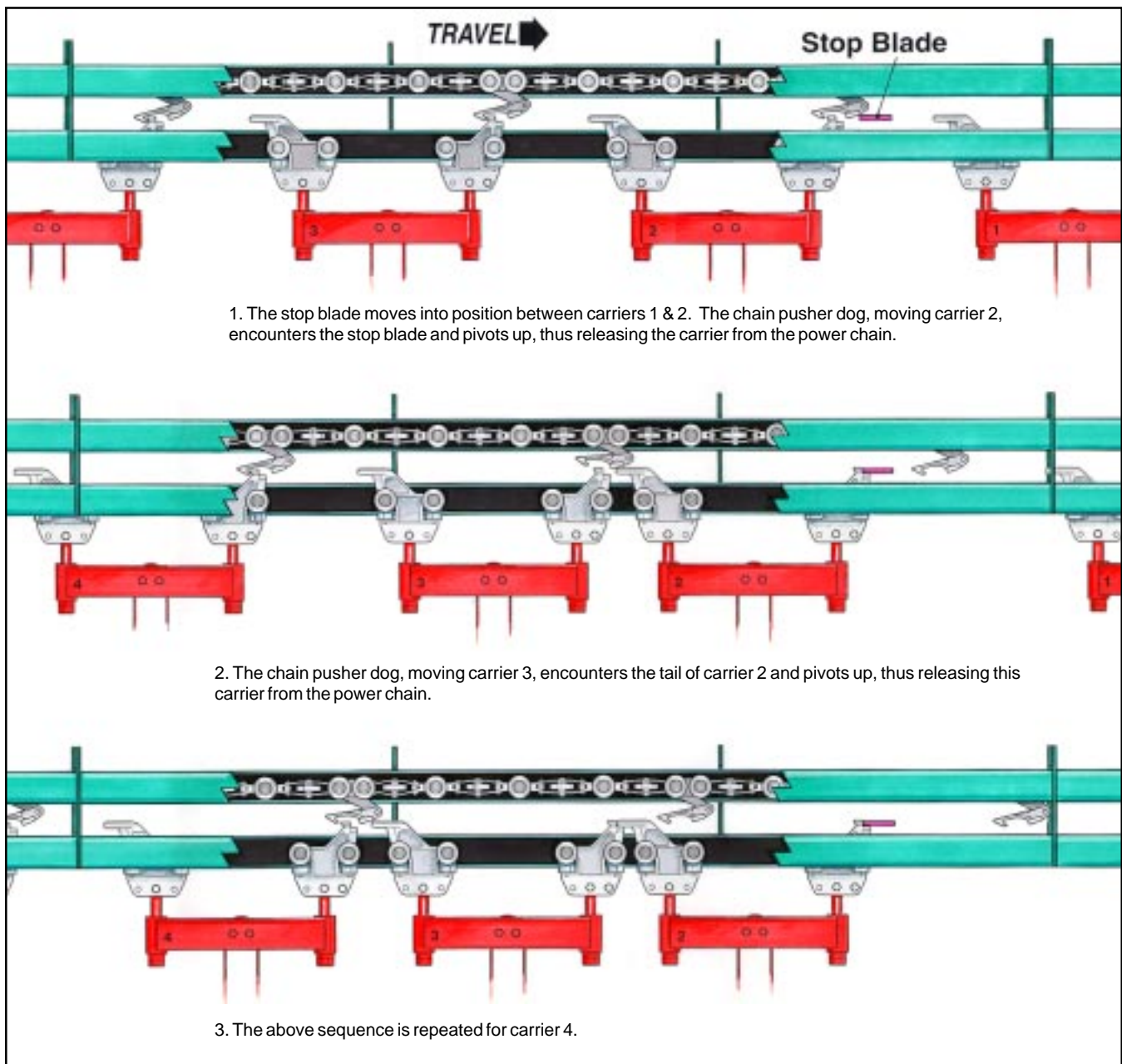



## Inverted Power & Free Conveyors

Inverted power & free is a variation of Unibilt's overhead Stop-N-Flow conveyor. The inverted system not only offers all the advantages of power & free, but it actually provides a cleaner product environment as well. Because the power track is located underneath the carrier, dirt and oil from the track cannot contaminate the product. Furthermore, because the product is supported from beneath, there is no carrier obstruction to the top and sides of the product. Inverted power and free is especially suited to conditions in which an overhead system cannot be used, for example, where space is limited, or when an existing structure cannot support an overhead conveyor.

The inverted power and free is simpler than most other floor-mounted systems because it doesn't require trans-

fers and elevators: flow is reversed by 180 degree turns, rather than transfers, and vertical curves replace elevators.

The floor-mounted inverted power & free conveyor has built-in flexibility that provides for balanced operations, material recirculation, parts accumulation, carrier switching from line to line, and varying chain speeds to accommodate different production rates within a system.

Unibilt's inverted power & free conveyor also is readily adaptable to computer control, which provides positive control of all carriers in a system. The result: greater efficiency in scheduling, inventory, and material flow.

## Accumulation/2 Trolley Carriers

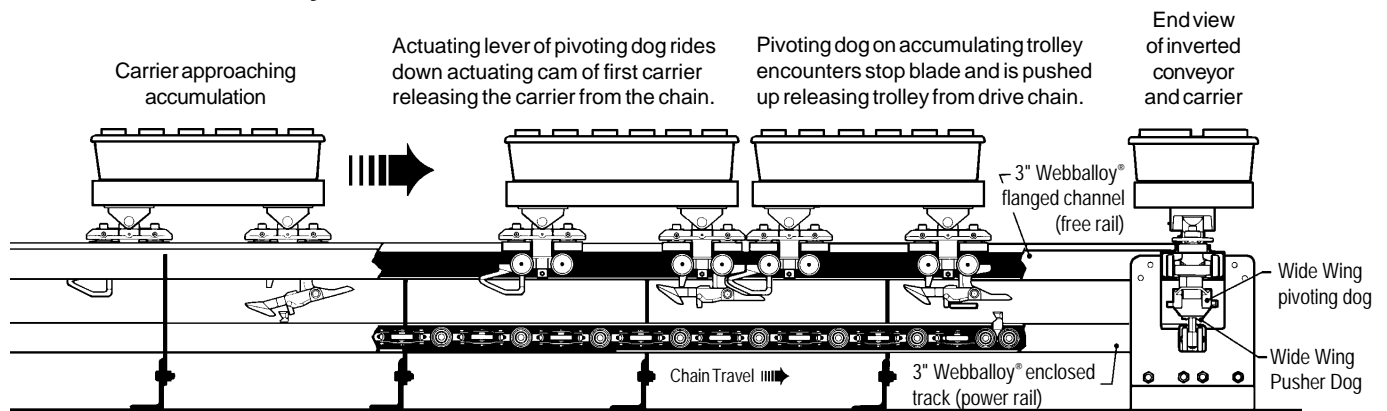



*Across the country, around the world,  
there's a Unibilt Sales Facility near you!*



*Jervis B. Webb Company, World Headquarters, Farmington Hills, Michigan*

**The Jervis B. Webb Company** has supplied Unibilt enclosed track conveyors to industry throughout the world for over 30 years. Jervis B. Webb offers design, fabrication and installation capabilities of its Unibilt enclosed track conveyors on a direct basis or through our extensive distributor network.

Our complete line of modular pre-engineered components are available through stocking distributors strategically located for quick delivery.

***For more information on Unibilt enclosed track conveyor equipment and systems call:***

***1-888-UNIBILT***  
***(1-888-864-2458)***

# Jervis B. Webb Company

MATERIAL HANDLING SYSTEM SPECIALISTS



## World Headquarters

Jervis B. Webb Company  
34375 W. Twelve Mile Rd., Farmington Hills, MI 48331-5624 USA  
1-888-UNIBILT FAX: 1-248-553-1253  
E-mail: [info@jerviswebb.com](mailto:info@jerviswebb.com)  
[www.jerviswebb.com](http://www.jerviswebb.com)

## North American Sales Offices:

### *Midwest*

34375 W. Twelve Mile Rd.  
Farmington Hills, MI 48331-5624 USA  
1-248-553-1295 FAX: 1-248-553-1261

### *South*

6407 Idlewild Road  
Suite 1.105  
Charlotte, NC 28212  
1-704-535-8866 FAX: 1-704-535-0170

### *East*

12 Main Street  
P.O. Box 0858  
Essex, CT 06426-0858  
1-860-767-7688 Fax: 1-860-767-7191

### *West*

153 West Lake Mead Drive  
Suite 3-102  
Henderson, NV 89015 USA  
1-702-566-5308 FAX: 1-702-566-5326

### *Canada*

1647 Burlington Street, East  
P.O. Box 3428 Station "C"  
Hamilton, Ontario, L8H 7M5 CANADA  
1-905-547-0411 FAX: 1-905-549-3798

## Global Sales:

### *Jervis B. Webb Worldwide Company*

34375 W. Twelve Mile Rd.  
Farmington Hills, MI 48331-5624 USA  
1-248-553-1224 FAX: 1-248-553-1237

---

Data given in this publication are intended only to aid the engineer in preliminary evaluations and is subject to change without notice.

All Trademarks™ and Registermarks® contained in this brochure are owned by Jervis B. Webb Company or its Subsidiaries.

# Adobe Acrobat Reader Tool Bar Descriptions



1 2 3 4 5 6 7 8 9 10 11 12 13 14 15 16 17 18 19 20 21 22 23 24

1. Open file ..... Opens selected file
2. Save file ..... Saves active file
3. Print file ..... Prints active file
4. Create PDF on-line ..... Create PDF documents through Adobe.com
5. Find ..... Keyword search the document
6. Show navigation pane .. Opens Bookmark or Thumbnail tabs **see Navigation Pane**
7. First page ..... Goes to the first page of the active document
8. Previous page ..... Goes to previous page
9. Next page ..... Goes to next page
10. Last page ..... Goes to last page of document
11. Go to previous view ..... Goes to previous magnification view
12. Go to next view ..... Returns to next view
13. Hand tool ..... Navigate around a magnified page view vertically and horizontally
14. Magnify tool ..... Enlarge specific area of page up to 1600%
15. Text selection tool ..... Select text to copy, if available
16. Graphic selection tool ... Select graphics to copy, if available
17. Zoom out ..... Zoom out to full page
18. View size ..... Displays current view size
19. Zoom in ..... Zoom in to magnify area up to 1600%
20. Actual size ..... Shows actual page size in window
21. Fit in window ..... Enlarges or reduces page to fit in window
22. Fit width ..... Enlarges width to fit in window
23. Reflow text ..... Reflow text within document, if available
24. Rotate view ..... Rotates window view of document

